

INSTALLATION NOTES

For cable sections using the RailEasy™ Swivel End, there must be a tensioner on one end and the total cable span may not exceed 25 feet (mid post required as specified).

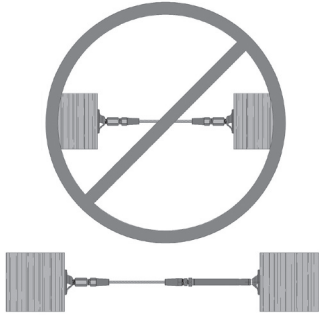

Follow the recommended tensioning sequence below to ensure proper installation and to achieve optimal results.

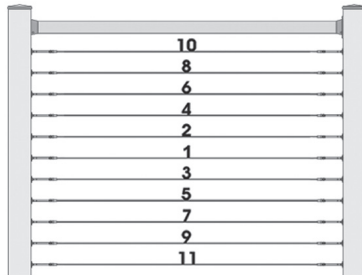

ORDERING

To aid in the process of ordering your cable railing system, an area has been provided on the back to sketch your project. We are happy to prepare a free take-off and quote for you.

Measure Your Cable Sections

Record each cable section length on your sketch. Maximum length for a straight section is 48 feet. Straight sections over 48 feet must be split.

Note: A "cable section" is the total length between end posts and corner posts, as well as, the total length between top and bottom stair posts.

Determine the Number of Cable Rows Needed

Measure the distance from the bottom of your top rail to the top of your bottom rail or mounting surface. Divide that measurement by 3. Round down to the nearest whole number and subtract 1.

Example: a 36" high railing with 34" between deck and bottom of the top rail.
 $34 \div 3 = 11.33$, round to 11 - 1 = 10 rows

DESIGN CONSIDERATIONS & CODE COMPLIANCY

The patented RailEasy™ Cable Railing System is designed to be used with existing or new wood posts. Make sure that all post material and attachments (rails) are constructed of approved materials per your local building code.

ALWAYS REFER TO YOUR LOCAL BUILDING CODE OFFICIAL PRIOR TO INSTALLING ANY ATLANTIS RAIL SYSTEM TO ENSURE ALL CODE AND SAFETY REQUIREMENTS ARE MET. ATLANTIS RAIL SYSTEMS IS NOT RESPONSIBLE FOR IMPROPER OR NON-RECOMMENDED INSTALLATIONS.

POST CONSTRUCTION & CONFIGURATION

End Posts and Corner Posts

Substantial end and corner posts are always necessary to prevent the posts from bending under the cable tension. A minimum of 4x4 (3-1/2" square) post is required. For straight cable sections using the RailEasy™ Tensioner at each end, you may run cable up to 48 feet in total length (mid posts required as specified).

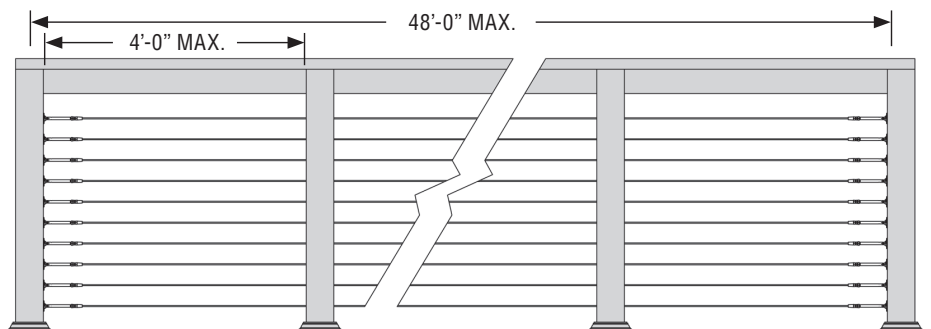

For straight cable sections using the RailEasy™ Tensioner at each end, you may run cable up to 48 feet in total length (mid post required as specified).

Mid Posts

Mid posts should be placed at intervals between end or corner posts. Atlantis Rail requires mid posts be placed every 4 feet to maintain cable spans with minimum deflection. A Cable Stabilizer Kit can be used to maintain code compliant cable spacing between posts with spacing greater than 4 feet and not exceeding 7 feet. The Cable Stabilizer is not a structural component and is not a substitute for a post.

Rails

A top rail is always necessary when building a wood railing with cable railing infill. It is highly recommended to secure the top rail between the posts rather than simply placing the rail on top of the posts. Bottom rails are optional but can provide more support and allow for a foot rest.

RAILEASY™ Quote Request Form

Name _____
 Phone _____
 Email _____
 State _____
 Zip Code _____
 Railing System Model _____

 Railing Height _____

Providing accurate information is the best 1st step in receiving an accurate and detailed quote. Please fill in the information requested to the left and sketch out your project below. After all the necessary information is filled in, please fax or email this form to (508) 732-9798 or info@atlantisrail.com.

Some cable railing basics to remember when requesting or reviewing a quote:

- Cable spacing is always 3 inches or less.
- Post spacing over 4 feet will require additional hardware to accommodate deflection. Atlantis Rail will provide recommendations if post spacing is exceeded.
- When accommodating existing rails, customer built wood rails or other variables, such as curbs or knee walls, the distance from the bottom of the top rail to the top of the bottom rail or mounting surface is needed.

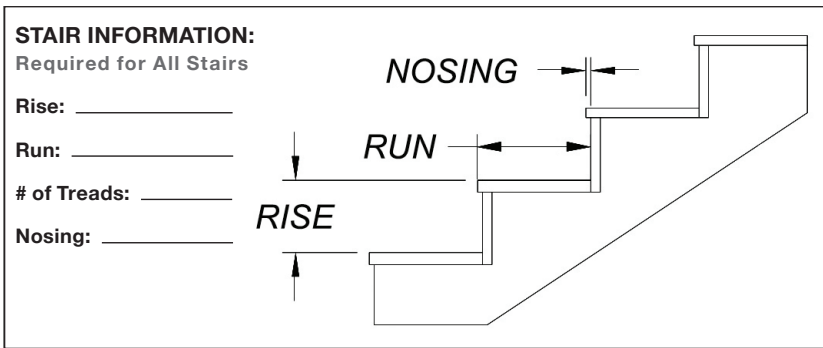

USE FOR A RAILEASY™ CABLE RAILING SYSTEM ON WOOD	# OF CABLES REQUIRED:	_____	x Cable Rows	=	_____
		Cable Section Length (in feet)			Total Cable (in feet)
	# OF RAILEASY™ TENSIONERS:	2 Per Cable Section Over 25'			# of 10 Packs
		1 Per Cable Section Under 25'			# of 2 Packs
# OF RAILEASY™ SWIVEL ENDS:	1 Per Cable Section Under 25'			# of 10 Packs	
				# of 2 Packs	