

**NOVA Nautilus System Installation Instructions**

The NOVA Nautilus System utilizes pre-drilled aluminum post sets with 2" stainless steel top and bottom rails. The rails are structural strength stainless steel so you can use it with just a top rail or you can add a bottom rail if preferred.

The following guide will take you step-by-step through the process of installing your NOVA Nautilus System. Along the way, we'll offer you tips and tricks to help you get your railing installed today and ready for tomorrow.

**Table of Contents**

<b>Tools</b>	<b>1</b>
<b>Tips for a Successful Installation</b>	<b>2</b>
<b>HandiSwage Components</b>	<b>2</b>
Additional Components	2
<b>Components for NOVA Nautilus Level Section</b>	<b>3</b>
<b>Preparation of Your Railing System</b>	<b>3</b>
<b>Level Post Installation</b>	<b>4</b>
<b>Level Rail Installation</b>	<b>5</b>
<b>Cable Stabilizer Installation</b>	<b>5</b>
<b>Cable Installation on Level Sections</b>	<b>6</b>
<b>Cable Installation on Corner Sections</b>	<b>8</b>
<b>NOVA Nautilus System Cable Mounting Hardware</b>	<b>8</b>
<b>Installing Cable Grommets</b>	<b>9</b>
<b>NOVA Nautilus System Accessories</b>	<b>9</b>
<b>NOVA Nautilus System Specifications</b>	<b>10</b>
<b>Posts, Cable Spacing &amp; Heights</b>	<b>10</b>
<b>NOVA Nautilus System Product Specifications</b>	<b>11</b>

 Deviation Note  
  Note  
  Requirement  
  Hint

**Tools**

**Required & Recommended**

								
Power Drill	Vice Grips	Hand Swage Tool	Miter Saw with Metal Cutting Blade	1/2" socket and ratchet wrench	Cable Cutter	#2 Phillips Driver Bit	17/64", 1/4" & 5/32" Drill Bits	3/8" & 7/16" Open Wrenches
								
3mm Allen Wrench	Level	Tape Measure	NOVA Nautilus Drilling Templates	Touch-up Paint	Chalk Line	Silicone Caulk	Hacksaw	HandiSwage™ Cutting Disk - 2pk
								
After Swage Gauge	Safety Glasses	Gloves	Grommet Install Tool	Combination Wrench 3/8" & 7/16"	Cable Grip Pad			

## Tips for a Successful Installation

- Read the instructions completely before beginning the installation.
- Plan your railing project. Sketch your project with the actual measurements of your deck or balcony complete with post locations.
- Check carton(s) to determine part count is complete.
- After cutting rails, cable stabilizers, or posts, paint exposed metal with rust resistant finish for maximum protection against elements.
- Installation is best accomplished with two (2) people.
- Always wear personal protection equipment; safety glasses, work gloves, etc.
- Use care not to over-torque the screws. Pre-drilling is recommended.
- Provided hardware to install the NOVA Nautilus System is for use with NOVA II aluminum posts. If installing to other surfaces, you must acquire the appropriate hardware as needed for proper installation.



*ATLANTIS RAIL SYSTEMS PROVIDES A VARIETY OF MOUNTING OPTIONS FOR POSTS AND RAILS USED IN OUR SYSTEMS. PRODUCTS OF THIS NATURE REQUIRE THAT MOUNTING SURFACES ARE CONSTRUCTED TO BE CONSIDERED STRUCTURAL PER BUILDING CODE DEFINITION FOR THE SURFACE MATERIAL USED. STRUCTURAL INTEGRITY AND BUILDING CODE COMPLIANCE OF MOUNTING SURFACES ARE THE RESPONSIBILITY OF THE END USER AND / OR INSTALLER. THE USE OF ANY OF OUR MOUNTING METHODS ARE AT THE OPTION AND DECISION OF THE END USER AND / OR INSTALLER AND SHOULD BE SELECTED TO MATCH THE STRUCTURAL MATERIAL USED TO CREATE THE MOUNTING SURFACE.*



**STORE YOUR ORDER INDOORS TO KEEP DRY!**  
*Some items in your order have been shrink wrapped with a protective poly film. Avoid exposing these items to harsh weather and moisture to avoid damaging powder coated surfaces. When you're ready to install product, remove the protective shrink wrap before or immediately after installation.*



*ALWAYS REFER TO YOUR LOCAL BUILDING CODE OFFICIALS PRIOR TO INSTALLING ANY ATLANTIS RAIL SYSTEM TO ENSURE ALL CODE AND SAFETY REQUIREMENTS ARE MET. ATLANTIS RAIL SYSTEMS IS NOT RESPONSIBLE FOR IMPROPER OR NON-RECOMMENDED INSTALLATIONS.*

## HandiSwage Components



C0731-H0703-2  
C0731-H0703-10

HandiSwage Standard Stud 1/8" (1/4"-28 RH) - 2 Pack  
HandiSwage Standard Stud 1/8" (1/4"-28 RH) - 10 Pack

## Additional Components



NOVA II  
Cover Nut Sets



Cable Grommets

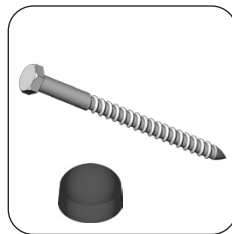

NOVA Post Mounting  
Hardware Kit

## Components for NOVA Nautilus Level Section

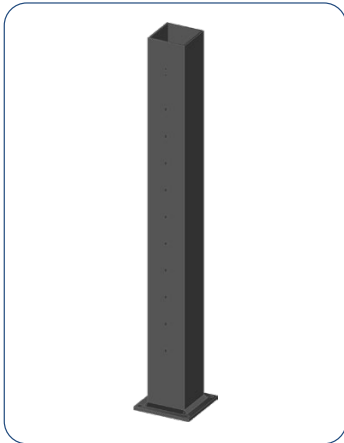

A. 36" Universal Post, Drilled

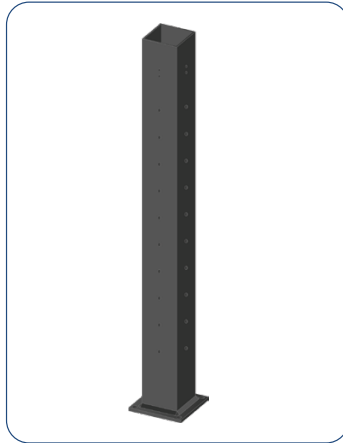

B. 36" Corner Post, Drilled

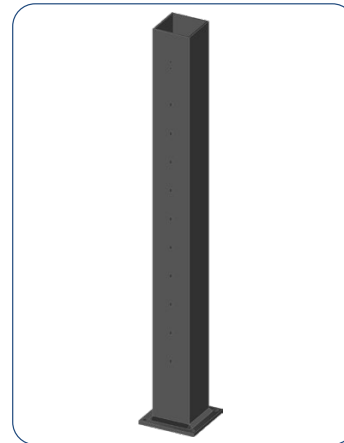

C. 42" Universal Post, Drilled

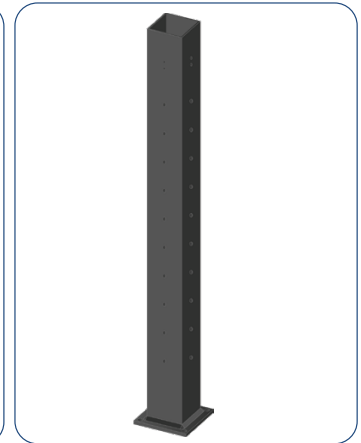

D. 42" Corner Post, Drilled

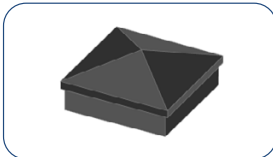

E. Post Cap

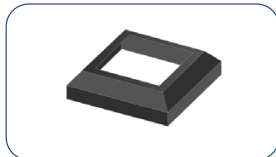

F. Post Skirt



G. Post Pad, Drilled

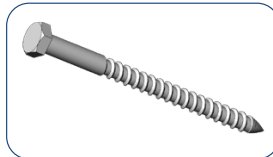

H. Lag Bolt (5/16" x 4-1/2")



I. Plastic Washer

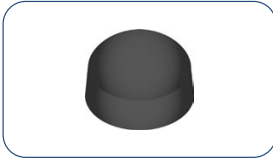

J. Plastic Cover Nut



K. Cable Grommet

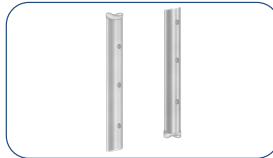

L. Cable Stabilizer (Top and Bottom Rails)

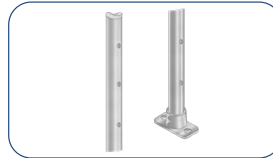

M. Cable Stabilizer (Top Rail)



N. Straight Sidemount Oval



O. Insulating Gasket



P. 2" 316L Stainless Steel Rail



Q. #10 x 1-1/2" Phillips Flat Head Screw

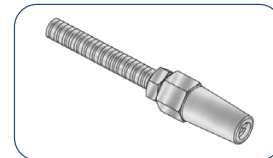

R. NOVA 1/8" Stud (part # P0908-0003)

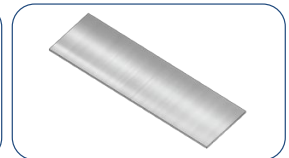

S. Post Shim

## Preparation of Your Railing System

### Must Know/Must Do

**CODE COMPLIANCE:** Always make sure you clear your project with the local code enforcement office and make sure your railing is ordered in accordance with their specifications. Code is usually universal but municipalities and states do often implement their own requirements.

Always use pencil for all lay out making.

### Rail Lay Out

The top and bottom rails are pre-cut for a 4' 6" section and the customer can cut to length as needed. You may increase rail spans up to 6' by adding a stabilizer kit for any span over 4' 6". Shorter or longer lengths of railing can be ordered by the foot. Contact your Atlantis Rail Sales Representative for details.

### Locate & Check the Parts of Your Rail System

When ready to install, take the time to make sure that the parts are included and undamaged. Report any inconsistencies to your building products supplier or Atlantis Rail Sales Representative as soon as you are aware of the issue.

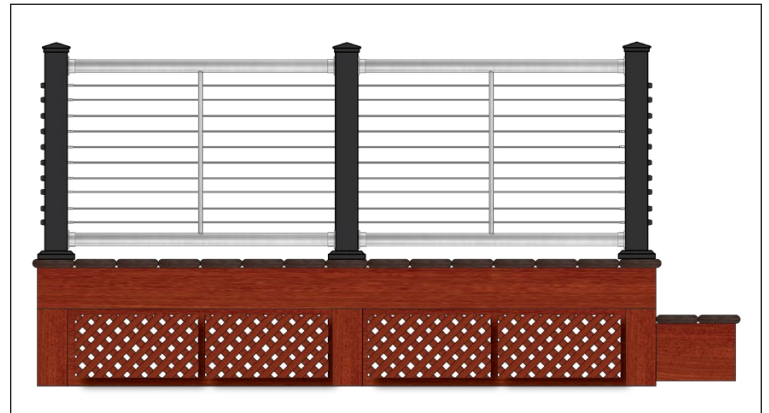

## Level Post Installation

### Pre-drill End, Corner and Mid Posts

Align the NOVA Nautilus drilling template against your post. Make sure the cable holes in the template are aligned with the cable holes already pre-drilled in the post. (There are separate drilling templates for both 36" and 42" posts).

For a top rail only (See Figure A) use a 5/32" drill bit to pre-drill the four (4) screw holes for the straight sidemount oval (Component N) to be mounted. You must also pre-drill the last cable hole located at the bottom of the template using a 1/16" drill bit (See Figure B).

If a bottom rail is desired (See Figure B) pre-drill the four screw holes for the straight sidemount oval to be mounted. The last cable hole located at the bottom of the template (See Figure B) does not need to be pre-drilled.



**PRE-DRILLING THE HOLES ON THE POST IS REQUIRED.**

### Locate & Install Level Posts

Measure and locate the position of the post(s) based on the project layout.

Install the post (Component A or B for 36" posts and Component C or D for 42" posts) by attaching the aluminum mounting flange to the mounting surface. Position the post so the fastener will go into the floor joist, and make sure the decking is firmly attached to the joist at the location of the post. If necessary, use wood blocking as reinforcement underneath the decking where the posts are located. Post mounting fasteners must be able to secure into the joist or reinforcement braces, not just the decking itself. When installing posts on top of a wood surface, lags must be into at least 3" of code compliant wood blocking.



**WHEN INSTALLING THE NOVA NAUTILUS SYSTEM ON TREATED WOOD SURFACES, INSTALL THE PROVIDED POST PAD (INCLUDED IN THE POST KIT) BETWEEN THE POST BASE AND THE TREATED SURFACE.**

Position the post on the mounting surface. Four (4) 3/8" diameter mounting holes are provided on the mounting flange. Mark the mounting flange hole locations and remove the post (See Figure C). Pre-drill the marked locations into the decking and reinforcement using a 1/4" drill bit. If the post pad (Component G) is being used, line it up with the pre-drilled holes. Mark the post pad center hole on the mounting surface, remove and pre-drill the marked location using a 1/4" drill bit. This will allow any water that builds up in the post to escape.

Remount the post assembly. Make sure the posts are positioned so the post holes are aligned properly to run cable and mount rails (Component P). Place provided post pad between the post and mounting surface (See Figure D). If using the NOVA Post Mounting Hardware Kit (A0908-HD10), insert the lag bolts (Component H) and secure the base to the

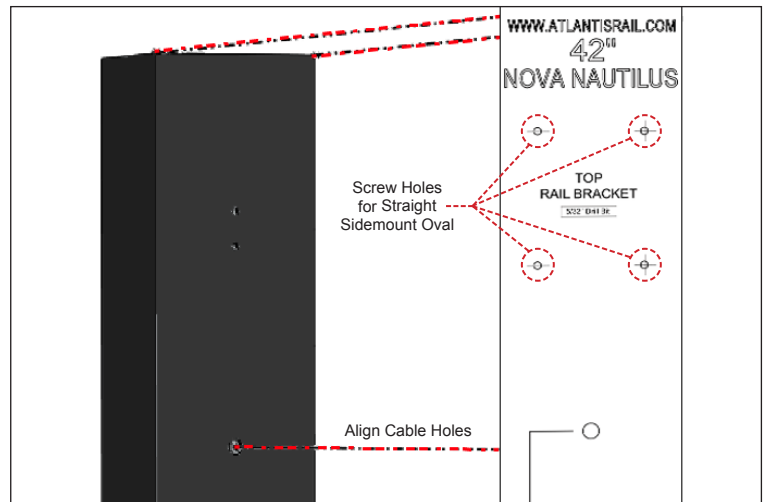

**Figure A.** Align the NOVA Nautilus drilling template against post and use a 5/32" drill bit to pre-drill your screw holes for the straight sidemount oval.

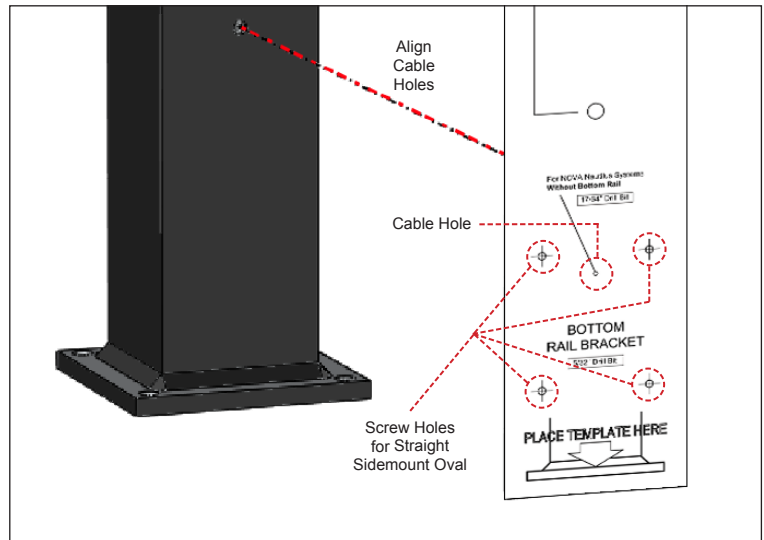

**Figure B.** Align the NOVA Nautilus drilling template against post and use a 5/32" drill bit to pre-drill your screw holes for straight sidemount oval. Pre-drill last cable hole using a 1/16" drill bit on post if installing top rail only.

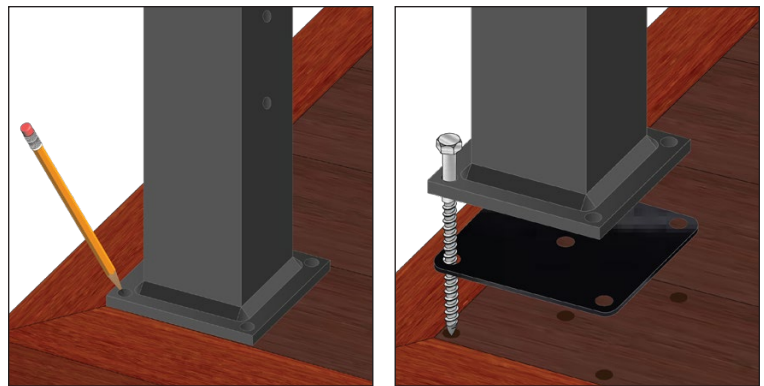

**Figure C. (LEFT)** When the final position is determined for the post, mark the hole locations of the four (4) 3/8" diameter mounting holes provided on the base and remove the post assembly.

**Figure D. (RIGHT)** Place post pad between the post and mounting surface.

mounting surface using a 1/2" socket and ratchet set. The lag bolt that is included in the NOVA Post Mounting Hardware Kit is 5/16" x 4-1/2". Avoid scuffing the posts with a drill gun or other tools. Make certain the posts are plumb. If the post requires adjustment, add add post shim(s) (part # A0906-SH01) (Component S) under the post pad. Once the posts are installed, apply silicone to the top of the lag bolts and secure the plastic cover nuts (Component J) to prevent moisture from getting below the post through the lag bolt holes (See Figure E).



**FOR MOUNTING ON CONCRETE, YOU MUST DETERMINE AND USE THE APPROPRIATE CONCRETE MOUNTING FASTENERS.**



**INSTALL POST SKIRT (COMPONENT D) BEFORE INSTALLING BOTH TOP AND BOTTOM RAILS.**

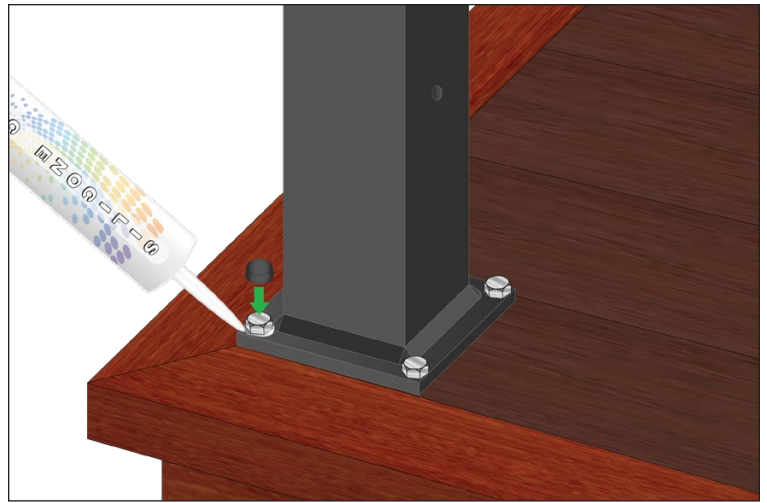

**Figure E.** Apply silicone to the top of the lag bolts and secure the lag bolt caps to prevent moisture from penetrating the holes.

## Level Rail Installation

### Install Straight Sidemount Oval Fittings

Loosen set screws using a 3mm Allen wrench and slide a sidemount fitting on either end of the appropriate rail with the flange facing outward (See Figure G).

Locate the previously pre-drilled holes at the top and bottom of each post. Install using four (4) #10 x 1-1/2" Phillips flat head screws (Component Q) (See Figure F).

With one sidemount installed, slide the other fitting against the opposite post. Slide it up or down until level. Install sidemount in place and recheck for level (See Figure H).



**INSTALL INSULATING GASKET (COMPONENT O) BETWEEN THE POST AND STRAIGHT SIDEMOUNT OVAL FITTING (SEE FIGURE F).**

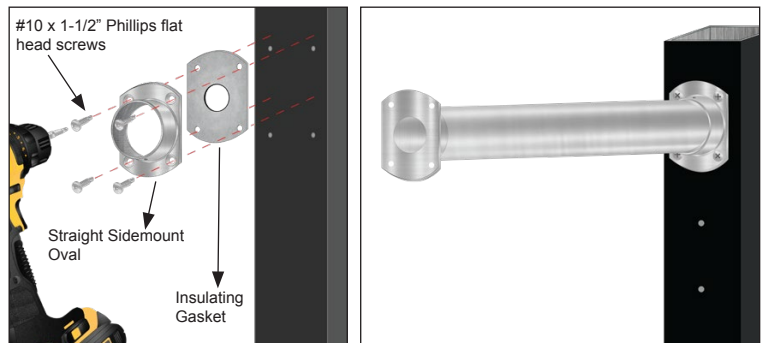

**Figure F. (LEFT)** Install using four (4) #10 x 1-1/2" Phillips flat head screws.

**Figure G. (RIGHT)** Loosen set screws and slide a sidemount fitting on either end of the appropriate rail with the flange facing out.

Slide the rail between sidemount fittings and tighten set screws to prevent the rail from rotating. Repeat previous steps for each straight rail section you have (top and bottom).



**TO AVOID STRIPPING THE SCREW, START DRIVING IT IN WITH A POWER DRILL, THEN FINISH WITH A SCREW DRIVER.**



**LONGER DRILL BITS OR USING A DRILL BIT EXTENSION MAY HELP KEEP THE HEAD OF THE DRILL FROM INTERFERING WITH THE SIDEMOUNT FITTING.**

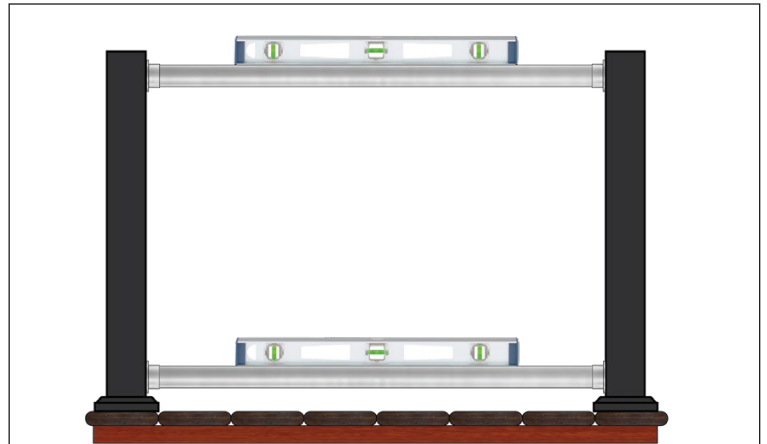

**Figure H.** With one sidemount installed, slide the other fitting against the opposite post. Slide it up or down until level

## Cable Stabilizer Installation



**IF THE BETWEEN POST MEASUREMENT IS 4' 6" OR UNDER, A CABLE STABILIZER IS NOT NEEDED.**

NOVA Nautilus System with both top and bottom rails will require a cable stabilizer (Component L) for spans over 4' 6" (See Figure I) and mounts to the top and bottom rails.

A railing system with only a top rail will require a cable stabilizer (Component M) for spans over 4' 6" and mounts to the top rail and mounting surface. Additional cutting of the stabilizer length may be required.

Refer to the Cable Stabilizer Kit Installation Instructions for detailed information on how to properly install cable stabilizers.



**THE CABLE STABILIZER KIT CANNOT BE USED TO REPLACE THE USE OF SUBSTANTIAL MID POSTS AND SHOULD NEVER BE USED IN SPANS OVER 6'.**

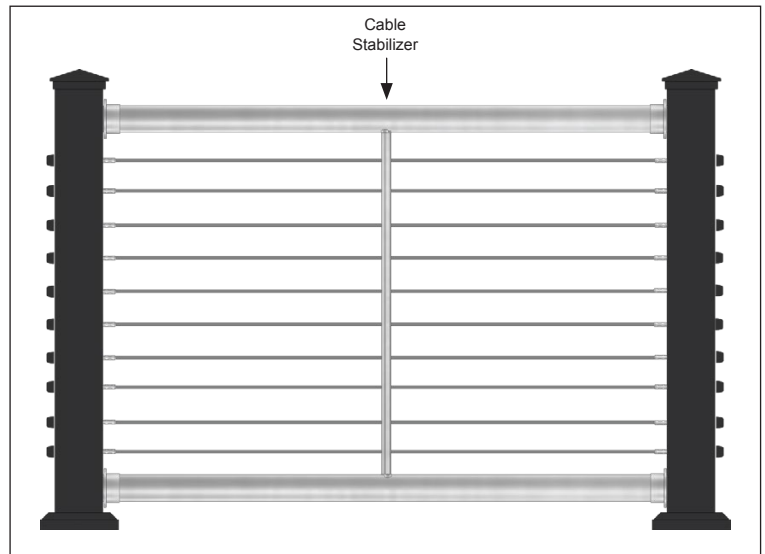

Figure I. Use a cable stabilizer for spans over 4' 6".

## Cable Installation on Level Sections

### Running the Cable

Beginning at the top, attach the cable to the HandiSwage Stud (part # C0731-H0703-2; C0731-H0703-10) in accordance with the hand swaging tool instructions.



**FOLLOW ALL WARNINGS AND WEAR PROPER SAFETY EQUIPMENT WHEN WORKING WITH CABLE TO PREVENT INJURY.**

Using the NOVA II Cover Nut Set, place the plastic washer, nut and lock nut on the end of the HandiSwage Stud threaded shank. Hand tighten until 1/2" of thread extends beyond the nut (See Figure J). Set aside the cover for installation later.

On the other end of the cable run, place the plastic washer and nut on the end of another HandiSwage Stud. Leave the tensioning nut as much travel as possible. Put the stud against the

opposite post and pull the cable tight by hand to the back of the stud. Mark and cut the cable at the notch before the threads (See Figure K). Swage the second fitting in accordance with the swaging tool instructions. Feed the cable through all intermediate stabilizers and posts.

Repeat the above steps until all the cables are run **BEFORE** applying tension.

### Tensioning the Cable

Before tensioning any of the cables, it is important to be sure that the frame for the NOVA Nautilus System is completed. Make sure the posts are installed securely and in accordance with the recommended installation procedures in the previous steps. Install all top and bottom rails. The posts will deflect beyond allowable limits if you attempt to tension the cables on an incomplete railing system. Before tensioning with tools, hold the stud fittings firm and tighten the nuts by hand until all cables are snug.

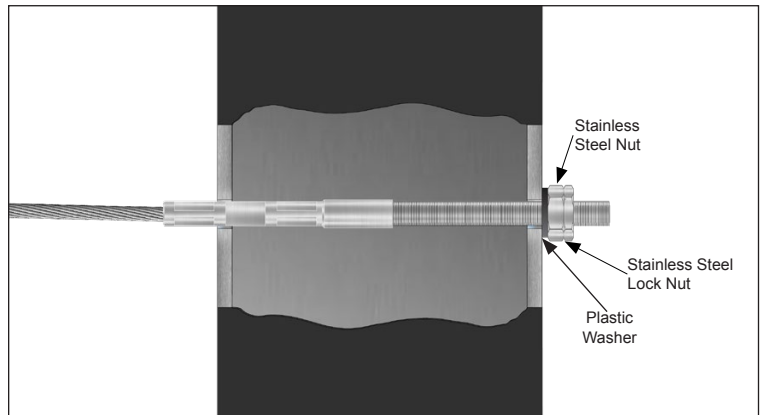

Figure J. Attach the first cable to the HandiSwage stud. Place the plastic washer, nut and lock nut on the end of the shank.

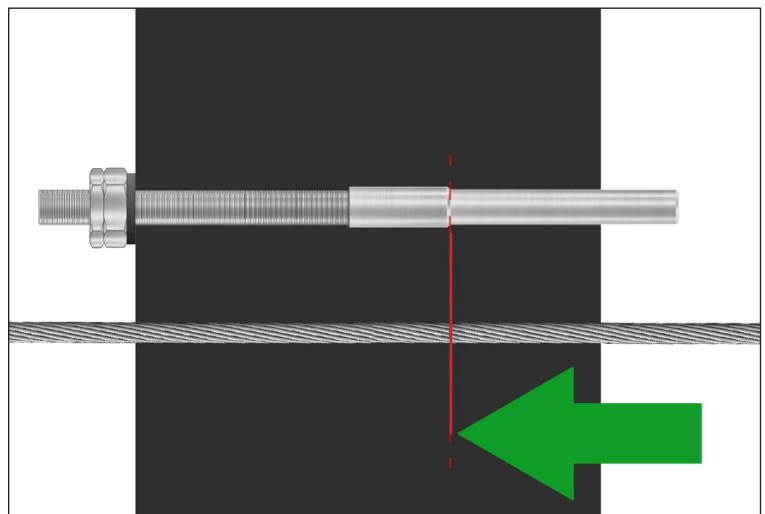
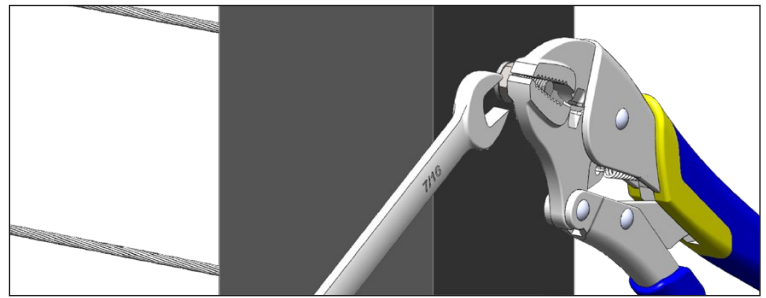

Figure K. Pull the cable tight to the back of the swage fitting. Mark and cut the cable as shown. Swage the second fitting in accordance with the swaging tool instructions.

When tensioning the cable, you must hold the stud or cable in a neutral position while turning the nut to apply tension. There are two (2) methods to accomplish this; both requiring a pair of vice grip pliers. Option one (1) is to hold the back of the swage stud with the vice grips which requires at least 1/4" space between the tensioning nut and the end of the stud (See Figure L). Option two (2) is to use a Cable Grip Pad (part # E0114-0000) to hold the cable just outside the post while you tension the stud using the tensioning nut (See Figure M).



**Figure L.** Option one (1) is to hold the back of the stud with vice grips while tightening the nut.



**USING METHOD TWO (2) REQUIRES A HANDISWAGE CABLE GRIP PAD. NEVER CLAMP PLIERS OR VICE GRIPS DIRECTLY ON THE CABLE.**

Set the vice grips with a 1/8" space total between the cable and the vice grip jaws. Place the pad on the cable and then apply the vice action to the pliers.

#### Tension the Center Cable

Beginning with the center run of cable. Hold the hand swage stud firm using one (1) of the methods described in the previous step and tighten the tensioning nut with a 7/16" wrench. Tighten the nut three (3) or four (4) full rotations until the cable is snug. **Do not over-tension!** Don't worry if this cable moves a little, we will come back around to it later.

#### Tension the Remaining Cables

Alternate tensioning the cables from the center, working above and below the center cable as if tightening the lug nuts on a tire (See Figure N). Again tension the nuts three (3) or four (4) full rotations or until the cable is snug. You will notice as you tension, the cables surrounding it will slacken. When this happens, stop tensioning and move onto the next cable.

#### Make Final Adjustments

Go back to the center cable and re-tighten the cables until all are tight and relatively equal in tension. You may find that you need to do this three (3) or four (4) times getting down to even a quarter turn of the tensioning nut each time. Tension from both sides when necessary.

#### Install the Cover Nuts

With the cables tensioned, it's time to install the lock nuts and cover nuts. Using the HandiSwage Combination Wrench (part # C0731-TK01-2) hold in place the nut with the 7/16" end of the wrench and tighten the lock nut with the 3/8" end of the wrench. Using a hacksaw or HandiSwage™ Cutting Disk, cut the remaining shank flush with the stainless steel lock nut. Then place the cover nut over the assembly until it is flush with the post (See Figure O).

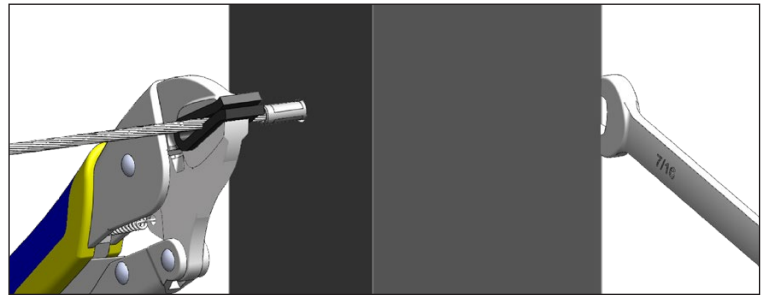

**Figure M.** Option two (2) is to use a cable grip pad to hold the cable just outside the post while tightening the nut.

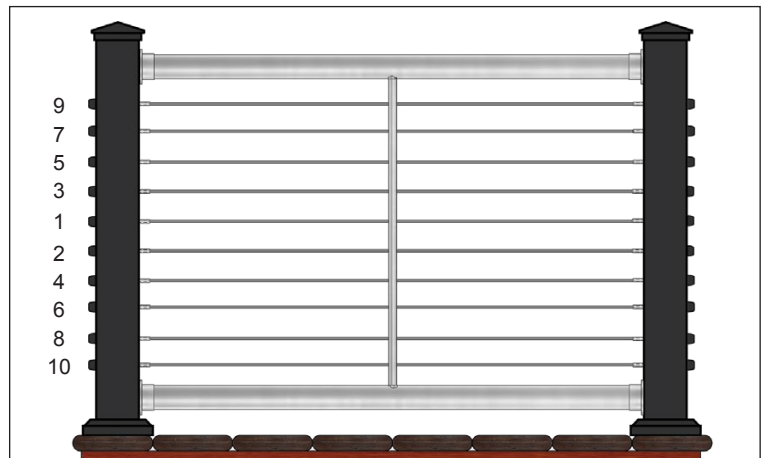

**Figure N.** Begin with the center run of cable and alternate working above and below until all the cables are tight.

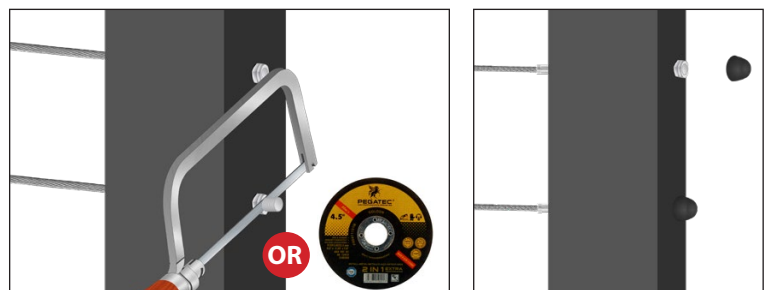

**Figure O.** Cut the remaining shank flush with the lock nut, then place the cover nut over the assembly.

## Cable Installation on Corner Sections

### Install the RailEasy 1/8" Stud

Locate the side of the corner post (Component B or D) with the threaded holes. Including the plastic washer (Component I, supplied), insert the RailEasy 1/8" Stud (Component R) into the corner post hole and thread it into the corner post insert (See Figure P).



**THE NOVA 1/8" STUD (PART # P0908-0003) MUST HAVE A HANDISWAGE STUD AT THE OPPOSITE END OF THE CABLE RUN IN ORDER TO TENSION THE CABLE.**

With the NOVA 1/8" Studs (part # P0908-0003) installed in the corner post, insert the cable into the receiver cone. Push and twist the cable opposite the lay of the wire strands. The cable should slide into the receiver cone approximately 3/16" past the bottom of the wedge (See Figures Q and R). Fully tighten the receiver cone onto the threaded stud using a 7/16" and 3/8" open wrenches. Upon doing this, the wedge will crimp down on the cable and hold it in place.

With the cable installed in one (1) NOVA Stud, pull the cable to the opposite HandiSwage Stud. Follow the instruction in the "Cable Installation on Level Sections" to install the HandiSwage Studs.

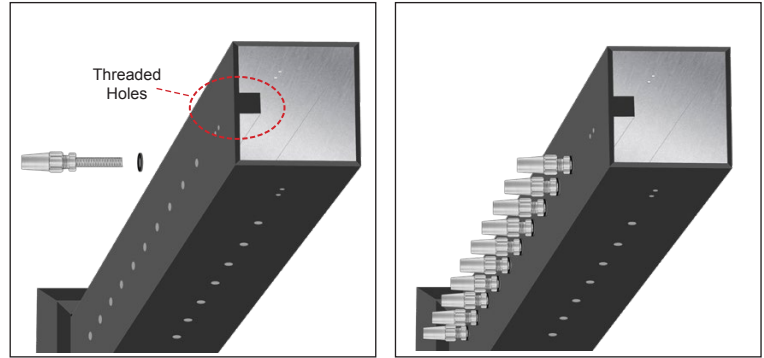

**Figure P.** Insert the NOVA 1/8" Stud (part # P0908-0003) into the corner post hole and thread it into the corner post insert.

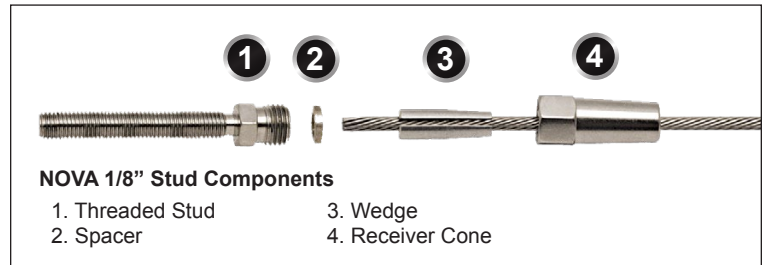

**Figure Q.** Exploded view of the NOVA 1/8" Stud (part # P0908-0003) for easy identification of each component.

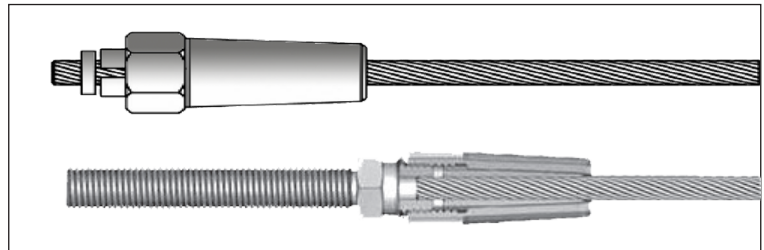

**Figure R.** Cutaway view of the NOVA 1/8" Stud (part # P0908-0003).

## NOVA Nautilus System Cable Mounting Hardware

### HandiSwage Stud – C0731-H0703-2; C0731-H0703-10

The HandiSwage Stud is the main tensioning component on the NOVA Nautilus level sections (See Figure S). Attach the cable to the hand swage stud in accordance with the hand swaging tool instructions. Affix a NOVA II Cover Nut Set to allow for tensioning of the cable. Available in packs of two (2) and ten (10).

### RailEasy 1/8" Stud - P0908-0003

The NOVA 1/8" Stud is the non-tensioning component on the NOVA Nautilus level sections (See Figure T). Attach the cable to the NOVA 1/8" Stud stud in accordance with the "Cable Installation on Corner Sections" instructions.

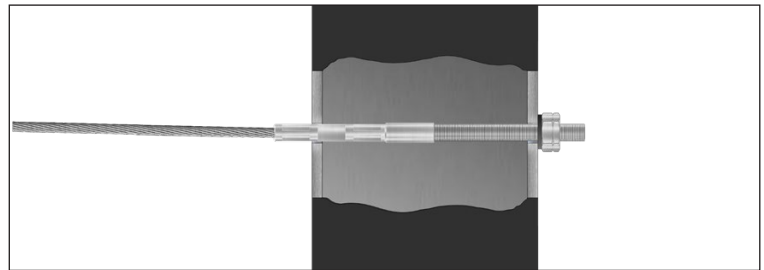

**Figure S.** The HandiSwage Stud is used on NOVA Nautilus level sections and features minimal hardware obstruction

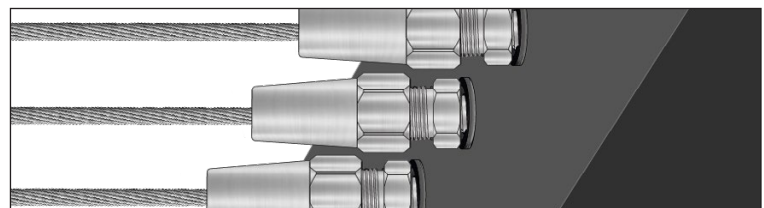

**Figure T.** The NOVA 1/8" Stud (part # P0908-0003) is used on NOVA Nautilus level sections and is mounted into the corner posts.

## Installing Cable Grommets

Utilizing the grommet install tool (part # E0916-1000) makes installing cable grommets easy.



**THE GROMMET INSTALL TOOL (PART # E0916-1000) ACCOMODATES BOTH 1/8" AND 5/32" CABLE GROMMET SIZES.**

Align the slot of the cable grommet with the slot of the cable grommet install tool (See Figure BC).



**NOT ALIGNING THE SLOTS OF THE CABLE GROMMET AND TOOL WILL NOT ALLOW THE CABLE GROMMET TO BE INSTALLED.**

Insert the flange of the cable grommet into the bottom side of the grommet install tool; making sure the slots are still aligned (See Figure BD).

Holding the grommet install tool in one hand and placing ones thumb on the top side of the cable grommet, push the cable grommet onto the cable in a downward motion. A little force will need to be applied to fit the cable grommet onto the wire (See Figure BE).



**ALWAYS POINT THE TIP OF THE CABLE GROMMET INWARDS TO THE POST HOLE AND KEEP THE POSITION OF THE SLOT DOWNWARDS TO ALLOW WATER TO DRAIN.**

After the cable grommet is placed onto the cable, remove the grommet install tool from the flange of the cable grommet. Place the grommet install tool on the wire (using the slot in the tool as a guide) push the cable grommet into the cable hole in the post until it fits flush (See Figure BF).

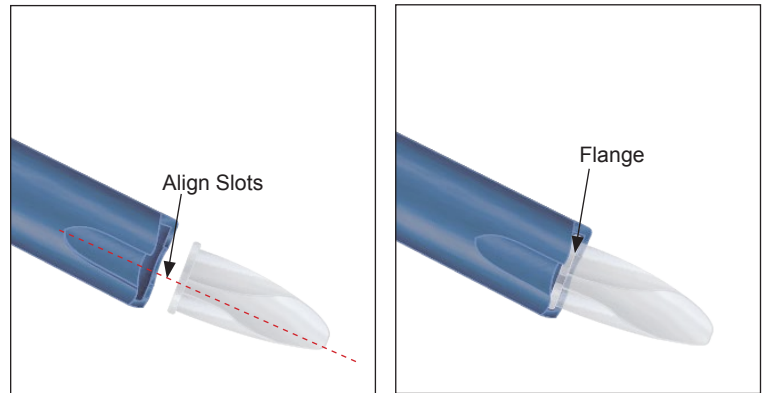

**Figure BC (LEFT)** Align the slot of the cable grommet with the slot of the tool. **Figure BD. (RIGHT)** Insert flange of cable grommet into the tool.

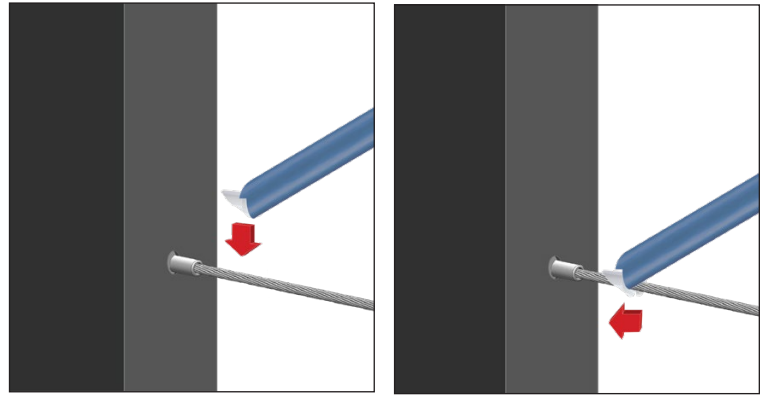

**Figure BE. (LEFT)** With the grommet install tool, push the cable grommet onto the cable in a downward motion.

**Figure BF. (RIGHT)** With the grommet install tool, push the cable grommet into the cable hole in the post until it fits flush.

## NOVA Nautilus System Accessories

### NOVA II Cover Nut Sets - C0906-XX02-10, C0906-XX02-12

The NOVA II Cover Nut Sets includes a plastic washer, stainless steel nut, stainless steel lock nut and plastic cover nut. They are used with the HandiSwage Stud for tensioning capabilities. Place the plastic washer and stainless nut onto the shank of the stud, tension, remove the excess thread and affix the plastic cover nut for a finished look (See Figure U). Available in black, white and bronze colors and in packs of ten (10) or twelve (12).

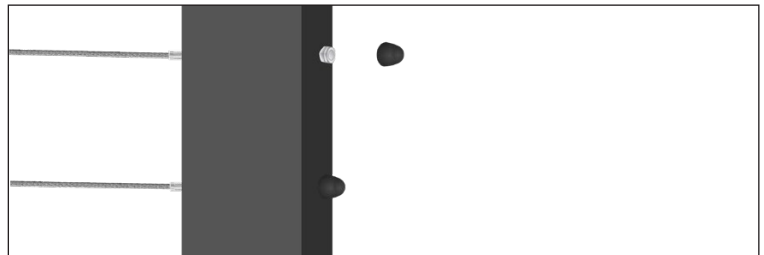

**Figure U.** Place the plastic washer, nut and lock nut onto the shank of the HandiSwage Stud, tension, remove the excess thread and affix the plastic cover nut.

### NOVA End/Corner Grommet - C0916-B003-10, C0916-B003-12

Once the cable has been installed and tensioned, it is time to add the cable grommets (part # C0916-B003-10, C0916-B003-12). The end/corner grommet (See Figure V) helps prevent movement and deflection of the cable, as well as, reduces dirt and moisture from getting inside the posts. These grommets are used on end and corner level posts (Components B & D). It fits over the HandiSwage Stud. These grommets are slotted for easy attachment onto the cable. Available in packs of twenty five (25).

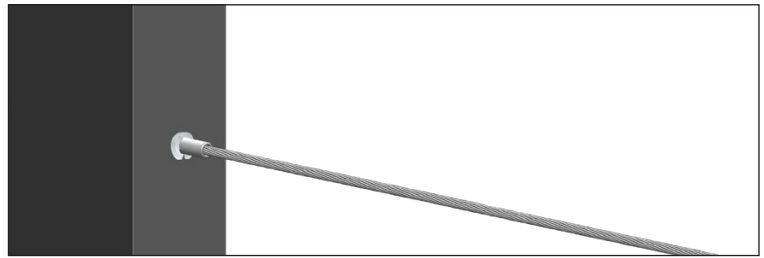

**Figure V.** The end/corner grommet helps prevent movement and deflection of the cable.

### NOVA Mid Grommet - C0916-0003-25

Once the cable has been installed and tensioned, it is time to add the cable grommets (part # C0196-0003-25). The mid grommet (See Figure W) helps prevent movement and deflection of the cable, as well as, reduces dirt and moisture from getting inside the posts. These grommets are used on the universal level posts (Components A & C) where the cable is passing through (not terminating with a HandiSwage Stud). These grommets are slotted for easy attachment onto the cable. Available in packs of twenty five (25).

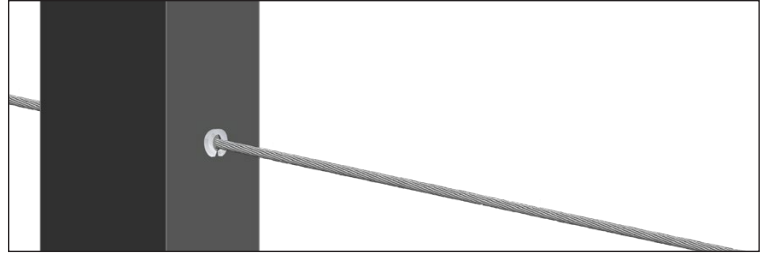

**Figure W.** The mid grommet helps prevent movement and deflection of the cable.

### Universal Stabilizer Mid Grommet - C0916-A003-25

Once the cable has been installed and tensioned, it is time to add the cable grommets (part # C0916-A003-25). This grommet (See Figure X) helps prevent movement and deflection of the cable, as well as, reduces dirt and moisture from getting inside the posts. These grommets are used on cable stabilizer (Components L & M) level sections. These grommets are slotted for easy attachment onto the cable. Available in packs of twenty five (25).

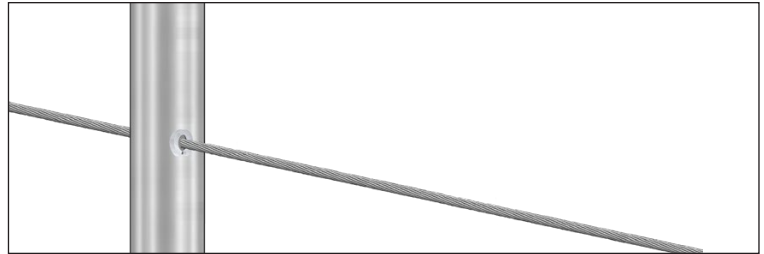

**Figure X.** The universal stabilizer mid grommet helps prevent movement and deflection of the cable.

## NOVA Nautilus System Specifications

The NOVA Nautilus System features powder-coated aluminum posts, 2" round stainless steel top and optional bottom rails and horizontal cable infill. The cable infill utilizes HandiSwage™ fittings with 1/8" cable. It is advised to observe that tension must be applied to fittings and cable. Posts should surface mounted securely enough to resist detachment and hold under tension.

### Straight Sections

The NOVA Nautilus System is offered in a standard post height of 36" or 42" for straight sections.

### Between Post Lengths

Atlantis Rail recommends staying within 4' section lengths (6' if using a cable stabilizer) to maintain structural integrity.

### Cable Spacing

The cable is spaced on the posts at 2-3/4" on-center to comply with nationwide building codes.

### Posts

The posts are offered in a powder coated black, white and bronze color options.

### Rails

The rails are 2" round 316L stainless steel tubing and come in a polished or brushed finish.

## Posts, Cable Spacing & Heights

Part Number	Post Description	Cable Spacing	Actual Post Height	Rendered Rail Height	Height From Surface
A0906-0036-XX*	NOVA II Universal Post 36"	2.75"	38.00"	36"	38.00"
A0906-0042-XX*	NOVA II Universal Post 42"	2.75"	44.00"	42"	44.00"
A0906-C036-XX*	NOVA II Corner Post 36"	2.75"	38.00"	36"	38.00"
A0906-C042-XX*	NOVA II Corner Post 42"	2.75"	44.00"	42"	44.00"

\* "XX" in the part number is the color designation. Replace with "BK" for black, "WH" for white or "BZ" for bronze.

# NOVA Nautilus System Product Specifications

Part Number	Description	Use	Notes
<b>Post Kits</b>			
A0906-0036-XX*	NOVA II Universal Post 36"	36" surface mount straight post	Black, White, Bronze
A0906-0042-XX*	NOVA II Universal Post 42"	42" surface mount straight post	Black, White, Bronze
A0906-C036-XX*	NOVA II Corner Post 36"	36" surface mount corner post	Black, White, Bronze
A0906-C042-XX*	NOVA II Corner Post 42"	42" surface mount corner post	Black, White, Bronze
<b>Rails</b>			
C0973-1800	RailEasy™ Tubing - 2" x 72" 316L Stainless Steel	6' straight top & bottom rails	Polished
S0900-0050**	RailEasy™ Tubing - 2" 316L Stainless Steel	Sold by the Foot	Polished
S0900-B050**	RailEasy™ Tubing - 2" 316L Stainless Steel	Sold by the Foot	Brushed
<b>Rail Fittings</b>			
C0975-0301-2	Straight Sidemount Oval - 316L Stainless Steel	Attaches rails to posts	Polished (2 Pack)
S0975-0301-B	Straight Sidemount Oval - 316L Stainless Steel	Attaches rails to posts	Brushed
S0975-0301-GASKET	Insulating Gasket	Acts as a barrier between the posts and the straight sidemount oval fittings	Grey plastic
<b>Cable Stabilizers</b>			
S0950-0061	Cable Stabilizer Kit for 2" Round Tubing on Nova Nautilus 1 - 316L Stainless Steel	Attaches to top rail and mounting surface	Polished
S0950-0062	Cable Stabilizer Kit for 2" Round Tubing on Nova Nautilus 2 - 316L Stainless Steel	Attaches to top and bottom rails	Polished
<b>Cable Mounting Hardware</b>			
C0731-H0703-2	HandiSwage Stud (2 pack)	Attaches to cable on level posts	Polished
C0731-H0703-10	HandiSwage Stud (10 pack)	Attaches to cable on level posts	Polished
A0908-0003	RailEasy 1/8" Stud	Attaches to cable on corner level posts	Polished
<b>Post Mounting Hardware</b>			
A0908-HD10	NOVA Post Mounting Hardware Kit	Surface mount posts on wooden surfaces	
<b>Accessories</b>			
C0916-B003	NOVA End/Corner Grommet (25 pack)	Grommet that attaches to HandiSwage Studs on end and corner level posts	
C0916-0003	NOVA Mid Grommet (25 pack)	Grommet attaches to cable and both sides of mid level posts	
C0916-A003	Universal Stabilizer Mid Grommet (25 pack)	Grommet that attaches to cable and cable stabilizers on level sections	
C0906-XX02-10* & C0906-XX02-12*	NOVA II Cover Nut Set (10 pack or 12 pack)	Use with HandiSwage Studs to tensioner and give a finished look	Black, White, Bronze
<b>Tools</b>			
E0916-1000	Grommet Install Tool	Grommet install tool makes installing cable grommets easy	
C0731-TK01-2	HandiSwage Combination Wrench 3/8" & 7/16"	Used to install the NOVA II Cover Nut Sets	

\* "X" in the part number is the color designation. Replace with "BK" for black, "WH" for white or "BZ" for bronze.

\*\* Customer supplied cut list.