

THE INFORMATION CONTAINED IN THIS DRAWING IS THE SOLE PROPERTY OF SUNCOR STAINLESS. ANY REPRODUCTION IN PART OR WHOLE WITHOUT THE WRITTEN PERMISSION OF SUNCOR STAINLESS IS PROHIBITED.

REVISIONS			
REV.	DESCRIPTION	DATE	APPROVED
A	RELEASED TO PRODUCTION	-21	JJS

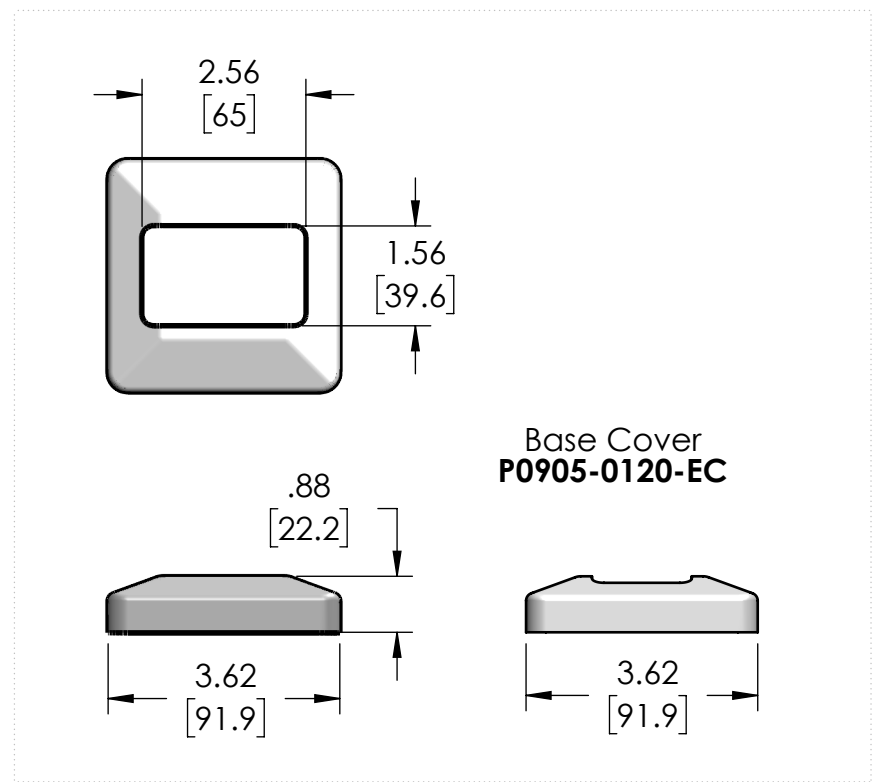

UNLESS OTHERWISE SPECIFIED DIMENSIONS ARE IN INCHES TOLERANCES ARE:			CAD GENERATED DRAWING DO NOT MANUALLY UPDATE	
FRACTIONS	DECIMALS	ANGLES	APPROVALS	DATE
$\pm 1/64"$.X ± 0.05 .XX ± 0.02 .XXX ± 0.005	$\pm 1/2^\circ$	DRAWN MGB	10-21-21
MATERIAL	316 SS	CHECKED J.STORRER	RESP ENG	-21
FINISH	SEE NOTES	MFG ENG		
DO NOT SCALE DRAWING		QUAL ENG		

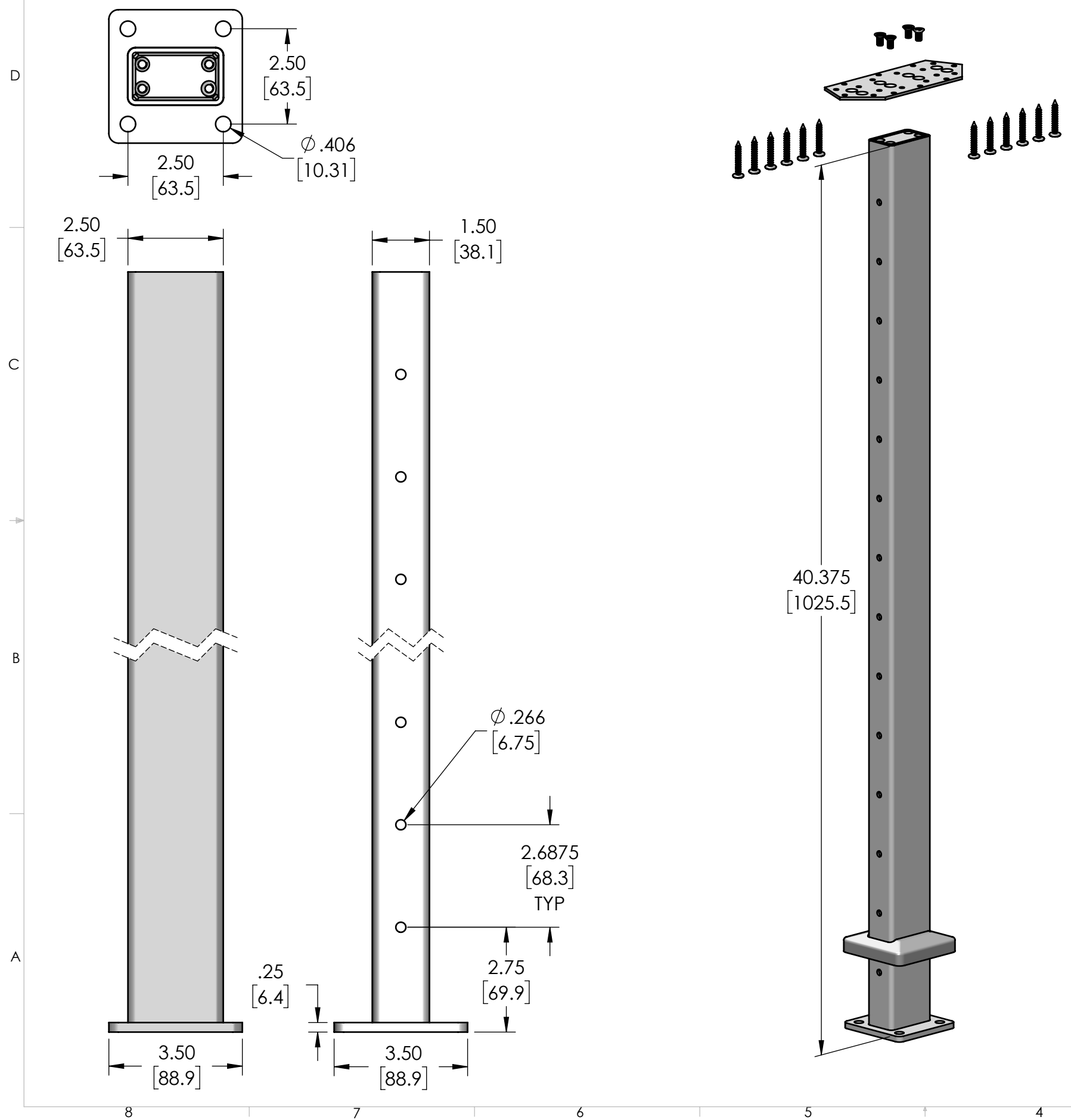

**SPECTRUM
42" END-CORNER POST**

SIZE B	DWG. NO. P0905-0042-EC	REV. A
-----------	---------------------------	-----------