

ATLANTIS RAIL Contact Information:

Atlantis Rail Systems

 70 Armstrong Road
 Plymouth, MA 02360

 3900 Civic Center Drive
 North Las Vegas, NV 89030

 (800) 541-6829 or  (508) 732-9191

 (508) 732-9798

 www.atlantisrail.com
RailEasy™ Nautilus Installation Instructions

The RailEasy Nautilus System combines the modern look of horizontal stainless steel cable and tensioners with the low maintenance quality of highly polished or brushed tubing and optional vinyl post components.

The following guide will take you step-by-step through the process of installing your RailEasy Nautilus System. Along the way, we'll offer you tips and tricks to help you get your railing installed today and ready for tomorrow.



Warning



Note



Recommendation



Hints

Table of Contents

Tools	1
Tips for a Successful Installation	2
RailEasy Components	2
Additional Components	2
Preparation of Your Railing System	3
Straight Section - Installing the Rails	3
Straight Section - Preparation	4
Straight Section - Installing the Cable	7
Straight Section - Tensioning the Cable	8
Straight Section - Installing Cover Nuts for RailEasy Stud Assembly only	9
Stair & Ramp Section - Installing the Rails	10
Stair & Ramp Section - Preparation	12
Stair & Ramp Section - Installing the Cable	13
Stair & Ramp Section - Tensioning the Cable	14
Additional Components	15
RailEasy Nautilus System Specifications	17
RailEasy Nautilus Product Specifications	17

Tools
Required & Recommended

Power Drill



#2 Phillips Driver Bit



1/4", 1/8", 3/16", 5/32" & 7/32" Drill Bits



Cable Cutter



Drill Extension



Carpenter's Square



Gloves



Safety Glasses



3/8", 5/16 & 7/16" Open Wrenches



3mm & 8mm (5/16") Allen Wrench



RailEasy Drilling Template



25' Tape Measure



Chalk Line



Level



Loctite® 326



Center Punch

Atlantis Rail offers a drilling template (C0988-1000) and installation tools (C0988-0000) to aid in your installation process. Ask your Sales Representative for more information.



Tips for a Successful Installation

- Read the instructions completely before beginning the installation.
- Plan your railing project. Sketch your project with the actual measurements of your deck or balcony complete with post locations.
- Check carton(s) to determine part count is complete.
- Installation is best accomplished with two (2) people.
- Always wear personal protection equipment; safety glasses, work gloves, etc.
- Use care not to over-torque the screws. Pre-drilling is recommended.



ATLANTIS RAIL SYSTEMS PROVIDES A VARIETY OF MOUNTING OPTIONS FOR POSTS AND RAILS USED IN OUR SYSTEMS. PRODUCTS OF THIS NATURE REQUIRE THAT MOUNTING SURFACES ARE CONSTRUCTED TO BE CONSIDERED STRUCTURAL PER BUILDING CODE DEFINITION FOR THE SURFACE MATERIAL USED. STRUCTURAL INTEGRITY AND BUILDING CODE COMPLIANCE OF MOUNTING SURFACES ARE THE RESPONSIBILITY OF THE END USER AND / OR INSTALLER. THE USE OF ANY OF OUR MOUNTING METHODS ARE AT THE OPTION AND DECISION OF THE END USER AND / OR INSTALLER AND SHOULD BE SELECTED TO MATCH THE STRUCTURAL MATERIAL USED TO CREATE THE MOUNTING SURFACE.



ALWAYS REFER TO YOUR LOCAL BUILDING CODE OFFICIALS PRIOR TO INSTALLING ANY ATLANTIS RAIL SYSTEM TO ENSURE ALL CODE AND SAFETY REQUIREMENTS ARE MET. ATLANTIS RAIL SYSTEMS IS NOT RESPONSIBLE FOR IMPROPER OR NON-RECOMMENDED INSTALLATIONS.

RailEasy Components



Additional Components



Acorn Nut Set



Deluxe Cover Nut Set



HandiSwage
Cover Nut Sets



RailEasy
Cable Sleeve

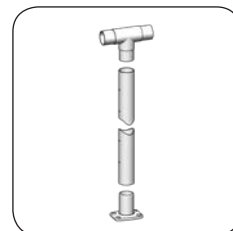

RailEasy Mid Post

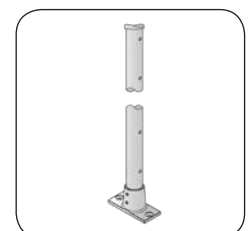

Cable Stabilizer

Preparation of Your Railing System

Must Know/Must Do

CODE COMPLIANCE: Always make sure you clear your project with the local code enforcement office and make sure your railing is ordered in accordance with their specifications. Code is usually universal but municipalities and states do often implement their own requirements.

It is always best to install your railings so the space between the deck and top rail or bottom rail and top rail are always evenly divisible by 3".

Always use pencil for all lay out making.

Rail Lay Out

If you requested Atlantis Rail to cut your top and bottom rails to your supplied dimensions, we will subtract 1/2" from each length to allow for mounting hardware. Your cut railings will be labeled with the actual cut size (your measurement less 1/2"). If there is additional work requiring engineering calculations, your rails will be labeled with a rail number. These additional calculations will usually be limited to Micro Star™ light installation, mid post installation or adjustable mounting brackets used for stair angles. If labeled per an engineered drawing, your labels will run from one specific end with top rail labeled UH-1 etc. and bottom rail labeled LH-1 etc. Stock length rails follow your own determined order and are cut in the field per your measurements.

Locate & Check the Parts of Your Rail System

When ready to install, take the time to make sure that the parts are included and undamaged. Report any inconsistencies to your building products supplier or Atlantis Rail Sales Representative as soon as you are aware of the issue.

Lay out your rails between the appropriate posts. Open the boxes of fittings and lay the appropriate fittings out along with the rails. Once all the parts are laid out and accounted for, you are ready to begin.

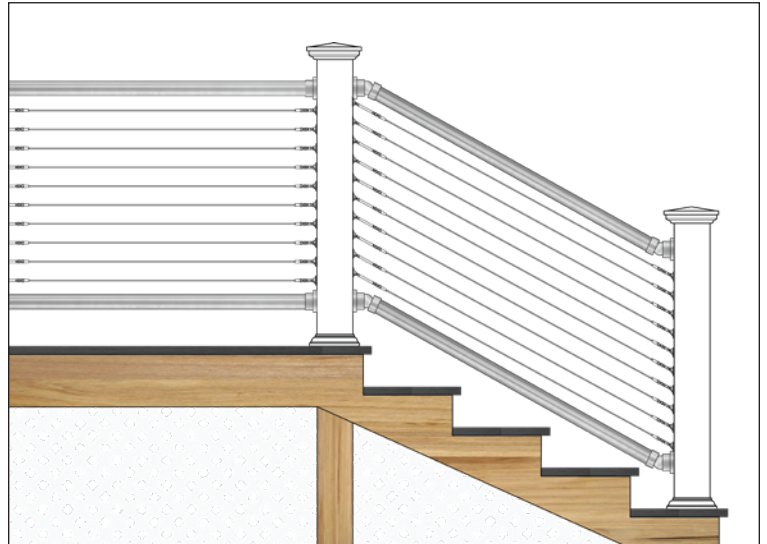

Straight Section - Installing the Rails



IF INSTALLING THE MICRO STAR LED LIGHTING, PLEASE REFER TO THE MICRO STAR INSTALLATION INSTRUCTIONS FOR RAILEASY SYSTEMS.

Must Know/Must Do

If you are installing your Rail Easy Nautilus with sleeved or clad post you need to complete all marking and drilling for mid post before installing your railings. Refer to page 5.

Find the Center of the Top Rail

Begin with the straight sections, saving the stairs for last. Use a square and a tape measure to mark the center of the first post. Make a vertical center line running the length of the post. For 36" systems, measure 35" from the mounting surface and mark a horizontal line on the post at this height. Measure 41" from the mounting surface for 42" systems. The intersection of these lines is the center point for your top rail (See Figure A). If installing a bottom rail, repeat at the desired lower rail height.

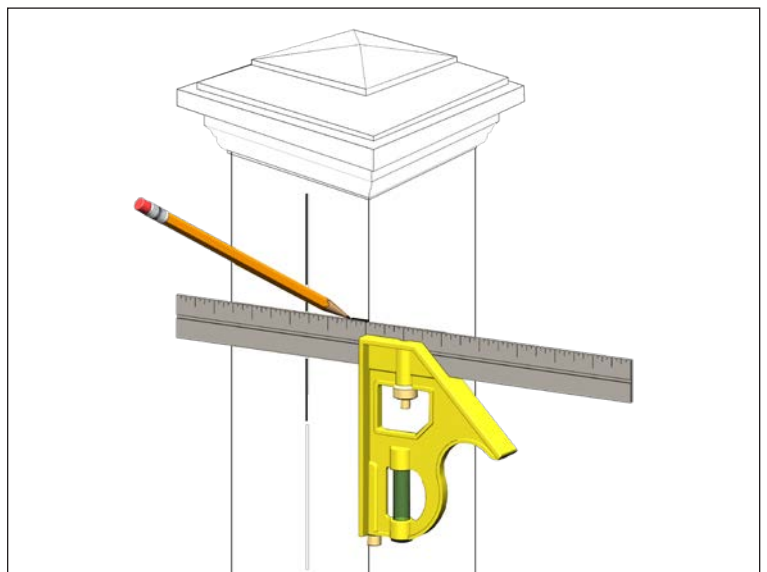

Figure A. Use a square and tape measure to mark the center of your posts.



SOUTHERN BUILDING CODES REQUIRE A BOTTOM RAIL SPACING OF NO MORE THAN 2".



ALWAYS USE WORK GLOVES AND WEAR SAFETY GLASSES TO PROTECT YOUR HANDS AND EYES WHILE WORKING WITH CABLE. DO NOT OVER-TENSION.

Must Know/Must Do

Building code in most jurisdictions calls for a 34 to 38" high railing for stairs regardless of what height the straight sections are. The objective is generally to achieve a 36" high hand rail. Code may vary and you must confirm required heights for stair sections before beginning your install.

Mark & Pre-Drill Holes for Screws

Using the straight sidemount fittings (C0975-0002), center the hole on the mark made in the previous step with the set screw facing down. Carefully mark the center of the three (3) screw holes. Remove the sidemount fitting and pre-drill the holes using a 1/8" drill bit.

Loosen set screws using a 3mm Allen wrench and slide a sidemount fitting on either end of the appropriate rail with the flange facing outward (See Figure B).

Install Sidemounts

Install using three (3) #10 x 1-1/2" screws (supplied). Slide the other sidemount fitting to the other post and lay flush against post.

With one sidemount installed, slide the other fitting against the opposite post. Slide it up or down until level. When level, mark and pre-drill holes as before. Install sidemount in place and recheck for level (See Figure C). Slide the rail between sidemount fittings and tighten set screws to prevent the rail from rotation. Repeat previous steps for each straight rail section you have (top and bottom).



LONGER DRILL BITS OR USING A DRILL BIT EXTENSION MAY HELP KEEP THE HEAD OF THE DRILL FROM INTERFERING WITH THE SIDEMOUNT FITTING.

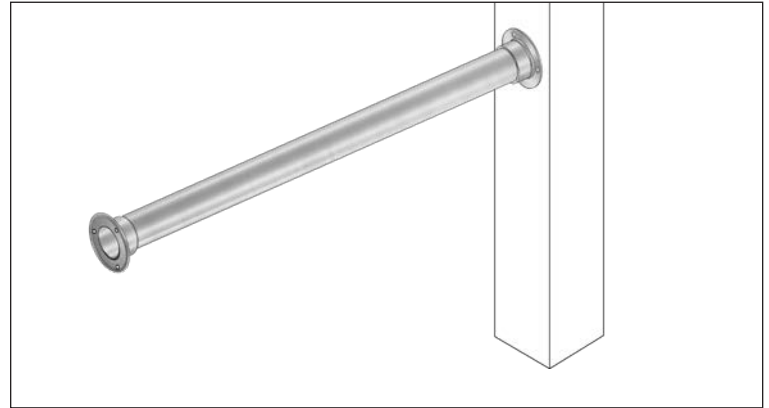

Figure B. Loosen set screws and slide a sidemount fitting on either end of the appropriate rail with the flange facing out.

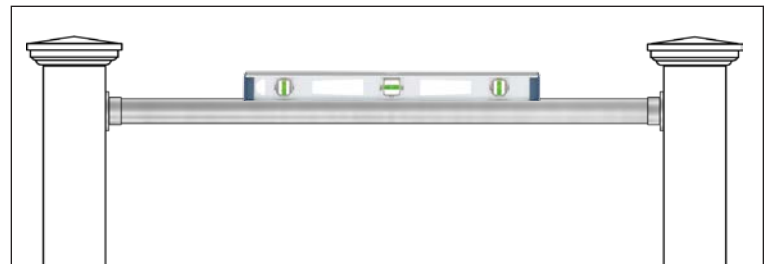

Figure C. With one sidemount installed, slide the other fitting against the opposite post. Slide it up or down until level.

Straight Section - Preparation

The infill for the RailEasy Nautilus is comprised of RailEasy fittings and horizontal cable. This section will show you how to install the infill between your posts.



IF INSTALLING CABLE STABILIZERS, PLEASE REFER TO THE CABLE STABILIZER INSTALLATION INSTRUCTIONS.

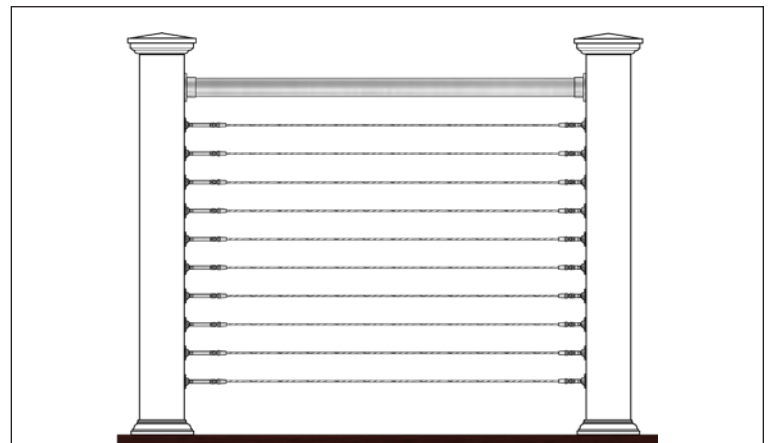

Atlantis Rail offers a drilling template (C0988-1000) to aid in your installation process. Ask your Sales Representative for more information (See Figure D).



RailEasy Tensioner (C0981 Series) & RailEasy Swivel End (C0981-S Series)

Space and Install the Tensioners & Swivel Ends

Determine the number of cable runs you will need to maintain code compliance. Check with your local building codes. Atlantis Rail requires spacing your cable at 3" on-center to ensure you will not have any building inspection issues. Using a square, find the center of the post face and draw a vertical line. Measure your spacing up from the mounting surface or top of the bottom rail to the underside of the top railing. Using the square, draw lines across the post face making sure they intersect with the center line you just drew (See Figure E). Repeat for each post. The drilling template makes this easier.

Next, place the center of a tensioner or swivel end on the intersection of each line and carefully mark the center of each screw hole (See Figure F). Remove and pre-drill the holes using a 1/8" drill bit. Fasten tensioners or swivel ends using (3) #8 x 1-1/2" screws (supplied). Install on all end and corner posts using equal spacing through. When installing tensioners or swivels end on straight sections, make sure the recess in the base is facing downwards. This will help to hide the recess.

Drill Through Mid Posts

Mark the centers of the mid posts on both sides in the same fashion as for finding the center of the tensioners. The intersections of these lines mark the centers of the through holes for the cable. Using a 7/32" drill bit, drill through approximately 2/3 of the post from either side (See Figure G). Drilling through both sides will give you a clean hole on each side and give you a cleaner installation. It is important that the holes you drill meet in the center of the post so accurate measurements are imperative.

With all the mid posts drilled though and tensioners or swivel ends mounted, you are ready to begin cable installation.



ATLANTIS RAIL REQUIRES SPACING YOUR CABLE AT 3" ON CENTER TO HELP AVOID ANY POTENTIAL BUILDING INSPECTION OR SAFETY ISSUES.



THE SWIVEL END MUST BE ACCOMPANIED BY A TENSIONING DEVICE ON THE OPPOSITE END OF THE CABLE RUN.

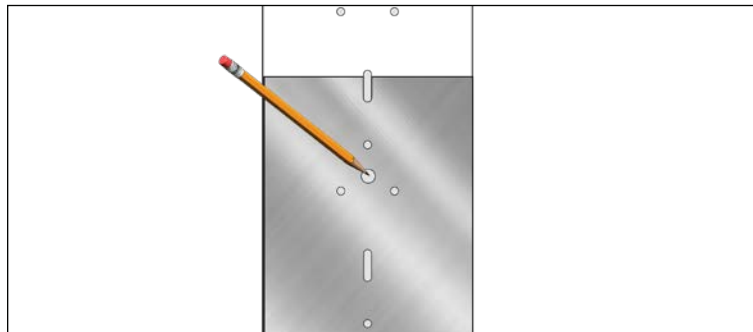

Figure D. Atlantis offers a drilling template to help you find your centers.

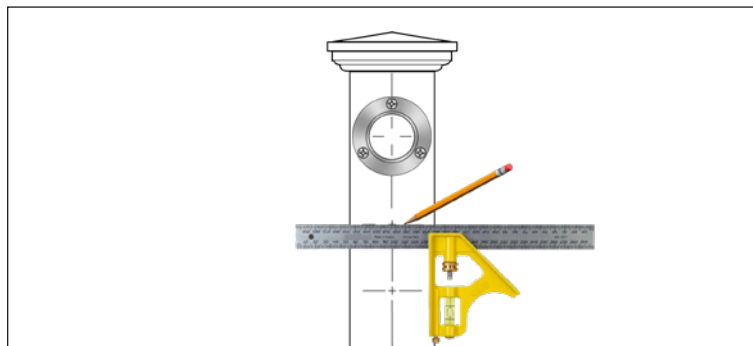

Figure E. Using the square, draw lines across the post face making sure they intersect with the center line you just drew.

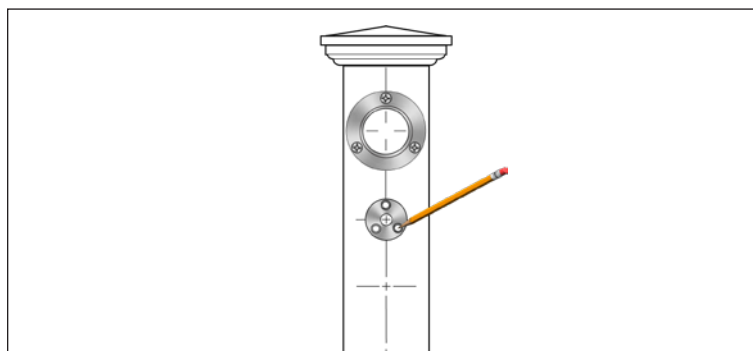

Figure F. Place the center of a tensioner on the intersection of each line and carefully mark the center of each screw hole.

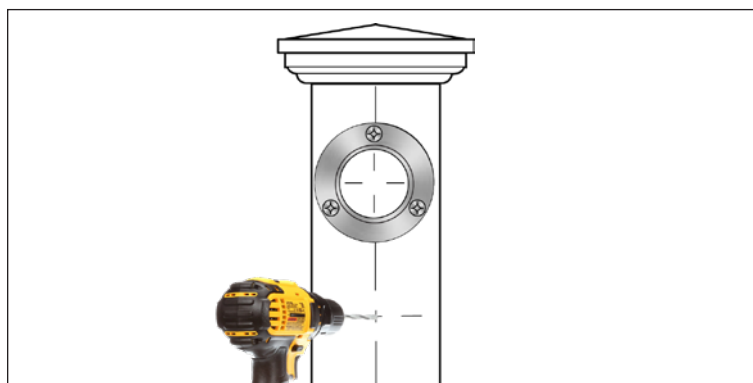

Figure G. For mid posts, use a 7/32" drill bit and drill through approximately 2/3 of the post from either side.

RailEasy Stud Assembly (C0980-0004-2)

The stud assembly is used in cable railing applications on straight runs. Using a 1/4" drill bit, drill through the post and install the stud assembly, fixing it to the back side (See *Figure H*). Tighten the locking nut to tension and cut off the excess thread to fit the Acorn Nut Set (standard). A Deluxe Cover Nut Set and HandiSwage Cover Nut Sets are also available for a desired finished look.

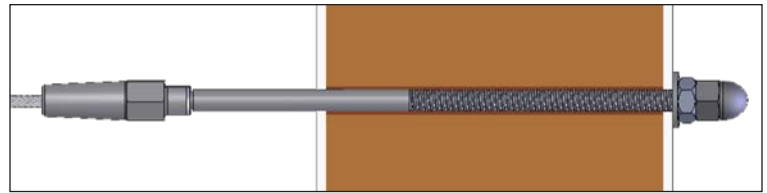

Figure H. Using a 1/4" drill bit, drill through the post and install the stud assembly.

RailEasy Flush Fitting (S0981-P004)

The flush fitting is designed to ease installation by eliminating the need for accurate measurement and swaging at one end of a cable run and is perfect for cable railing applications where "through post" hardware is desired for minimal obstruction. When using the flush fitting on one end you will re-drill the back end of the post (See *Figure I*) with a 7/16" bit approximately 1-1/4" deep to accept the flush fitting. See additional instructions on page 4 for running cable using the flush fitting. This fitting uses a mechanical swage design to attach to 5/32" diameter cable. The cable is pulled through the fitting and the excess is cut off. Affix the supplied stainless steel deluxe cap to the end for a finished look.

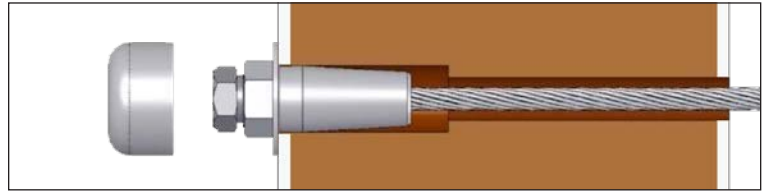

Figure I. Re-drill the back end of the post with a 7/16" bit to accept the flush fitting.

RailEasy Lag Stud (C0980-R004-2)

The lag stud is designed for use in short runs and must always be used with a RailEasy Tensioner at the opposite end of the cable run. With a 3/16" drill bit, drill approximately 1-5/8" deep to accept the lag stud (See *Figure J*). Using a 3/8" wrench, turn the lag stud until it is fully seated to the face of the post. These fittings are available with a right hand thread. The compression fitting holds the cable using simple hand tools. A left handed thread RailEasy Lag Stud is also available (S0980-L004).

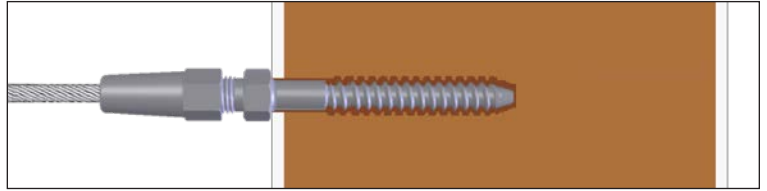

Figure J With a 3/16" drill bit, drill approximately 1-5/8" deep to accept the lag stud. Use a 3/8" open wrench on the flats of the stud to install into a wood post.



THE FLUSH FITTING AND LAG STUD MUST BE ACCOMPANIED BY A TENSIONING DEVICE AT THE OPPOSITE END OF THE CABLE RUN.

RailEasy Mid Post Kit and Cable Stabilizer Kit

More information is available in the Additional Components section found towards the end of these installation instructions. Refer to the Cable Stabilizer Kit installation instructions for detailed information on how to properly install cable stabilizers.



THE CABLE STABILIZER KIT CANNOT BE USED TO REPLACE THE USE OF SUBSTANTIAL MID POSTS AND SHOULD NEVER BE USED IN SPANS OVER 6'

RailEasy Cable Sleeve (C0915-0438)

More information is available in the Additional Components section found towards the end of these installation instructions. Refer to the Cable Sleeve installation instructions for detailed information on how to properly install cable sleeves.

Straight Section - Installing the Cable

Atlantis Rail offers cable cutters (C0989-00HD) to aid in the cutting of 5/32" cable. It is important that you use sharp tools to cut the cable, as a dull tool will splay it. Ask your Atlantis Rail Sales Representative for more information.



ALWAYS USE WORK GLOVES AND WEAR SAFETY GLASSES TO PROTECT YOUR HANDS AND EYES WHILE WORKING WITH CABLE. DO NOT OVER-TENSION.

RailEasy Tensioner (C0981 Series)

Measure & Run the Cable

With the tensioners installed (See Figure K), begin by extending the threaded stud outward a minimum of 3/4" for the first 20 feet plus 1/4" for each additional 10 feet. Insert the cable into the receiver cone, push and twist the cable opposite the lay of the wire strands. The cable should slide into the receiver cone until approximately 3/16" past the bottom of the wedge (See Figure L). Fully tighten the receiver cone onto the threaded stud using 7/16" and 3/8" open wrenches. Upon doing this, the wedge will crimp down on the cable and hold it in place. With the cable installed in one tensioner, pull the cable to the opposite tensioner. Pull the cable tight to the tensioner and cut it (See Figure M). Using the first run as a guide, cut the remaining runs to the same length. This will ensure uniformity among the tensioners. Thread the cable through each mid post and install the cable into the opposite tensioner using the same process as before.

RailEasy Stud Assembly (C0980-0004-2)

With the stud assembly installed into the post and required space to tension, insert the cable into the receiver cone, push and twist the cable opposite the lay of the wire strands. The cable should slide into the receiver cone until approximately 3/16" past the bottom of the wedge (See Figure N). Fully tighten the receiver cone onto the threaded stud using 7/16" and 3/8" open wrenches. Upon doing this, the wedge will crimp down on the cable and hold it in place. Pull the cable tight to the tensioner end of the stud assembly and cut it (See Figure N).

The stud assembly comes standard with the Acorn Nut Set but the Deluxe Cover Nut Set and HandiSwage Cover Nuts Sets are also available for the desired finished look.

RailEasy Swivel End (C0981-S Series)

The swivel end must be used in conjunction with a RailEasy Tensioner in order to tension the cable. Follow the same process as above to cut and install the cable (See Figure O).

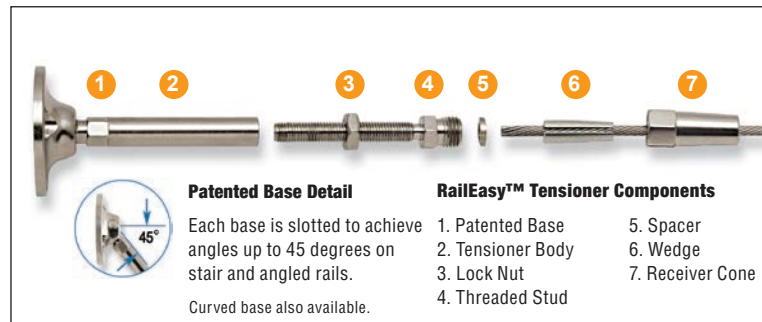

Figure AB. Exploded view of the RailEasy Tensioner for easy identification of each component.

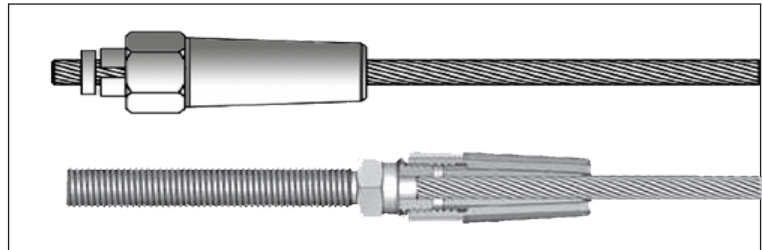

Figure L. Cutaway view of the RailEasy Tensioner

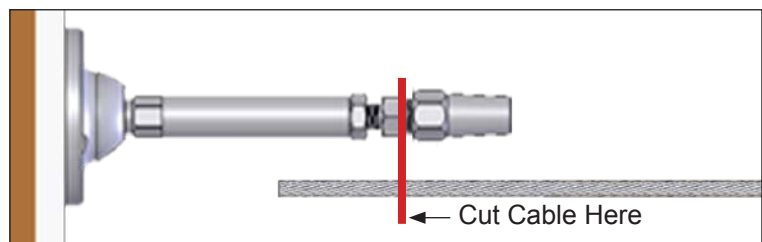

Figure M. Pull the cable tight to the tensioner and cut it.

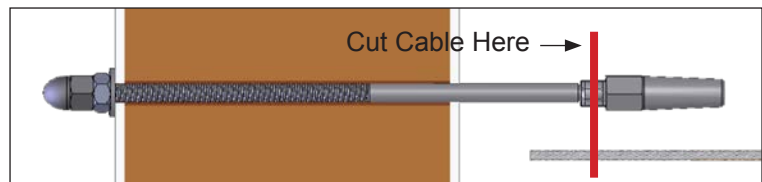

Figure N. Pull the cable tight to the tensioner end of the stud assembly and cut it.

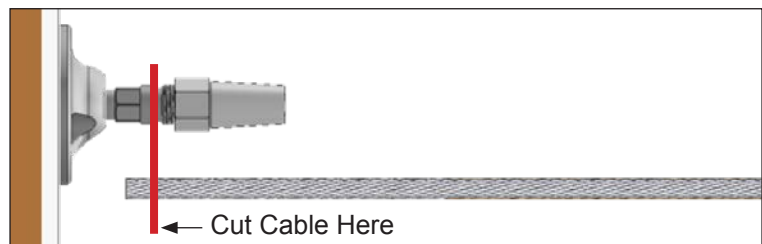

Figure O. Pull the cable tight to the swivel end and cut it.

RailEasy Flush Fitting (S0981-P004)

When using the RailEasy Flush Fitting, you must have a tensioning device on the other end of the cable run. If using the Flush Fitting measure the entire span from outside to outside of the cable run posts and add 2 inches beyond the post at the opposite end and cut your cable to that length. Attach one end of the cable to the RailEasy Tensioner or Stud Assembly. Run your cable to the opposite post where you have drilled the post to accept the flush fitting, going through all mid posts. At the opposite end, put the cable through the end post and through the flush fitting (See Figure P). Push the flush fitting against the back of the post and pull the cable tight before finger tightening the outside nut on the flush fitting.



USE A CABLE GRIP PAD WITH VICE GRIPS AT THE LAST MID POST TO HOLD CABLE TENSION WHILE IN-STALLING FLUSH FITTING (See Figure Q).

Using 3/8" and 7/16" wrenches, tighten the flush fitting onto the cable. Return to the opposite end and tighten your tensioner or stud assembly until there is no slack in the cable. Trim excess cable on the flush fitting with a hacksaw or grinding disk (cable must be flush with the flush fitting) and place the stainless cap on the completed flush fitting installation (See Figure R). Follow cable tensioning instructions below.

RailEasy Lag Stud (C0980-R004-2)

For the lag stud follow the same process as before to install the cable (See Figure S). The lag stud like the swivel end and flush fitting is the terminal end of the cable run and must be accompanied with a tensioning device on the other end of the cable run. Pull the cable tight to the lag stud end and cut it.

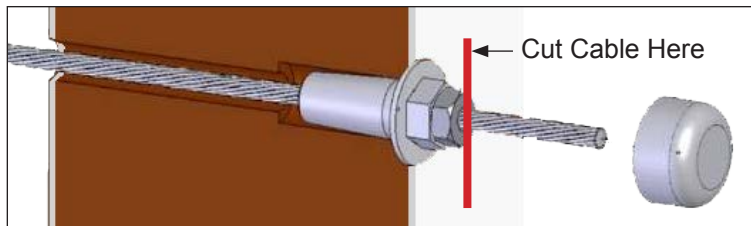

Figure P. Put the cable through the flush fitting. Push it against the back of the post and pull the cable tight and cut.

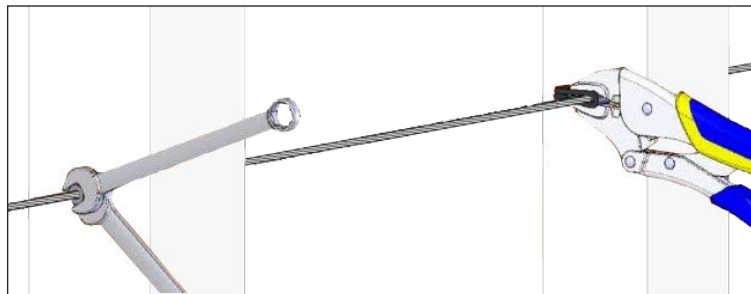

Figure Q. Use a cable grip pad with vice grips to hold the cable tight.

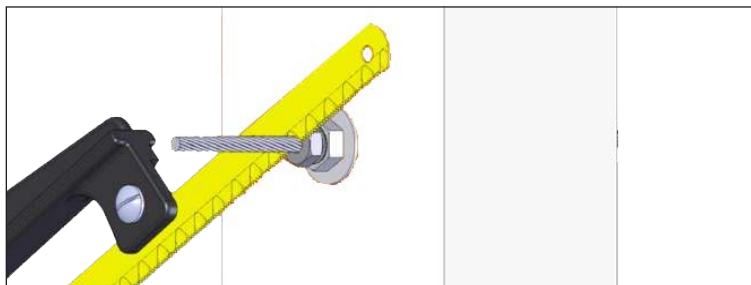

Figure R. Trim excess cable with a hacksaw or grinding disk in order to attach the cap for a finished look.

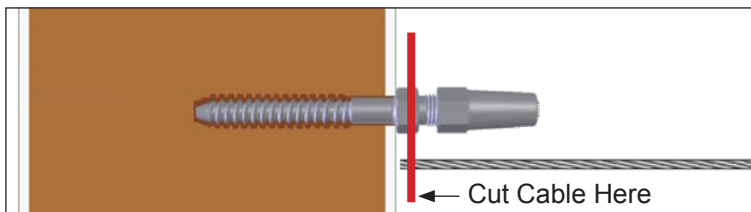

Figure S. Pull the cable tight to the lag stud end and cut it.

Straight Section - Tensioning the Cable



BEFORE TENSIONING ANY OF THE CABLES, IT IS IMPORTANT TO BE SURE THAT THE FRAME FOR THE INFILL IS COMPLETED.

Make sure the posts are installed securely and in accordance with the manufacturers' recommended installation procedures. Install all top and intermediate rails. The posts will deflect beyond allowable limits if you attempt to tension the cables on an incomplete guard frame. Before tensioning with tools, hold the stud fittings firm and tension the nuts of the system by hand until all cables are snug.

RailEasy Tensioner (C0981 Series)

Tension the Center Cable

Begin with the center run of cable. Using a 3/8" open wrench, hold the threaded stud in place and rotate the tensioner body

with a 5/16" open wrench. Tension each side equally until taut. Do NOT over-tension. Over-tensioning will cause posts to deform and deflect. When all cable runs are properly tensioned, tighten the lock nuts down to maintain tension.

When tensioning, it is important to begin with the center run of cable and alternate working above and below the center, much like tightening the lug nuts on a tire (Figure T). This will help to ensure that your posts don't deflect during tensioning. It will also help tension equally through. Continue tensioning all the cables in this same fashion until all cables are tensioned.

RailEasy Stud Assembly (C0980-0004-2)

With the RailEasy Stud Assembly installed into the post hold the nut (outside of the post) firm using a 7/16" open wrench.

Hold hex flats on Threaded Stud with a 5/16" open wrench. Place a wrench on hex flats of the stud assembly and rotate as needed. Tension cable equally from both ends of each cable span. Don't worry if this cable moves a little, we will come back around to it later. Tighten nut to secure tension, cut excess thread with a hacksaw and install the acorn nut for a finished look.

RailEasy Swivel End (C0981-S Series)

If using a swivel end, the opposite end of the cable assembly requires a tensioning device. The swivel end should be installed in the post and have cable installed in it. Follow the tensioning directions for the RailEasy Tensioner or Stud Assembly to tension the other side of the swivel end cable run.

Flush Fitting (C0981-P003-2)

If using a flush fitting, the opposite end of the cable assembly requires a tensioning device. The flush fitting should be installed in the post and have cable installed in it. Follow the tensioning directions for the RailEasy Tensioner or Stud Assembly to tension the other side of the flush fitting cable run.

Lag Stud (C0980-R004-2)

If using a lag stud, the opposite end of the cable assembly requires a tensioning device. The lag stud should be installed in the post and have the cable installed in it. Follow the tensioning directions for the RailEasy Tensioner or Stud Assembly to tension the other end of the lag stud cable run.

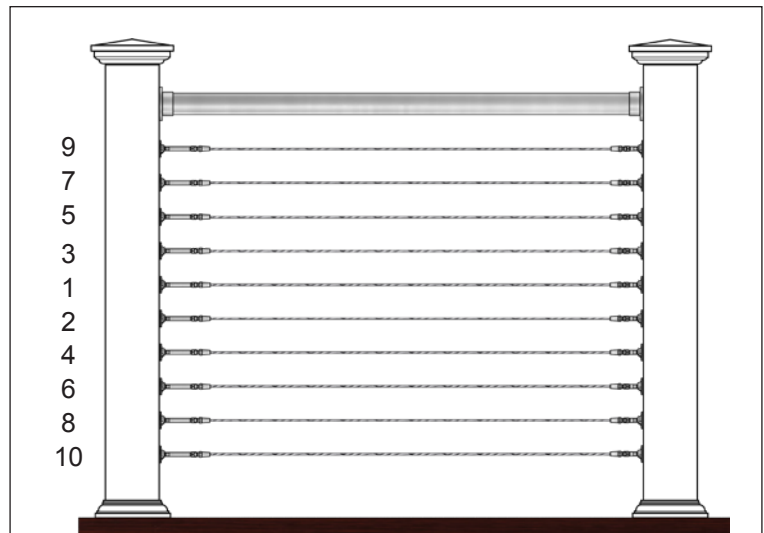

Figure T. Tensioning Diagram - Begin with the center run of cable and alternate working above and below until cables are tight.

Straight Section - Installing Cover Nuts for RailEasy Stud Assembly Only

Acorn Nut Set (C0308-UF07-2)

The Acorn Nut Set (See Figure W) are designed for use with RailEasy Stud Assemblies and comes with the RailEasy Stud Assembly. They are perfect for cable railing systems where "through-post" hardware is desired for minimal obstruction. Affix the stainless steel acorn nut set to the end of a stud assembly for a finished look. The Acorn Nut Set comes with a stainless steel nut and washer in packs of 2.



Figure W. Acorn Nut Set.

- 1) With the cables tensioned, it's time to install the cover nuts. This is accomplished in just three easy steps, and you just did one of them!
- 2) Using a hacksaw, cut the remaining shank off flush with the tensioning nut.
- 3) Then place the cover nut over the assembly until it is flush with the post (See Figure U).



Figure U. The Acorn Nut Set installs in just 3 easy steps: tighten, cut and cover.

In addition to the Acorn Nut Set, Atlantis Rail offers a Deluxe Cover Nut Set (C0307-UF07-2) and HandiSwage Cover Nut Sets (C0309 Series). More information is available in the Additional Components section found towards the end of these installation instructions.

Stair & Ramp Section - Install Rails

Installing the Top Rail

Start by marking your post. As before, begin with a square (See Figure V) and a tape measure to find the center of your post face at the mounting point of your top rail (35"). Using the same technique as before, measure from the surface of the deck up to the appropriate height and draw a full pencil line across the post, and an intersecting pencil line along the full length of the post. Measure 1.75" in each direction along your center lines and draw a 1 inch straight line in each position. Your RailEasy Adjustable Sidemount (C0976-0002) will fit between these lines. Repeat for each stair post. These hash marking will be your starting point for proper installation.



THE POSITIONING OF YOUR POST WILL EFFECT RATHER YOUR HASH MARKS WILL BE ADEQUATE TO ACHIEVE YOUR OBJECTIVE IS OF A 36" HIGH TOP RAIL. GENERALLY IF YOUR RISE AND RUN ON YOUR STAIRS ARE EQUAL AND YOUR POSTS ARE MOUNTED IN THE SAME SPOT TOP AND BOTTOM YOUR HASH MARKS WILL BE CORRECT.

Check one section at a time. Make sure the 8 mm cap screw in the cup of the is not loose, but also does not restrict the pivoting action (See Figure X). Before beginning this process make sure you have the correct length rail for the section in process. If you have helper proceed as follows. Insert the adjustable sidemount on each end. At the bottom the pivoting cup holding the rail should be pointed up and your helper can center it between your hash marks. For the top pivoting cup holding the rail should be pointed down. Once both ends are aligned check the measurement from the "nose" of the stair tread one in from the top and bottom post to assure they are at the level you desire. Adjust your height accordingly to your preference, usually 36". When both ends are at the desired height pencil mark the holes in the base of the adjustable sidemount.

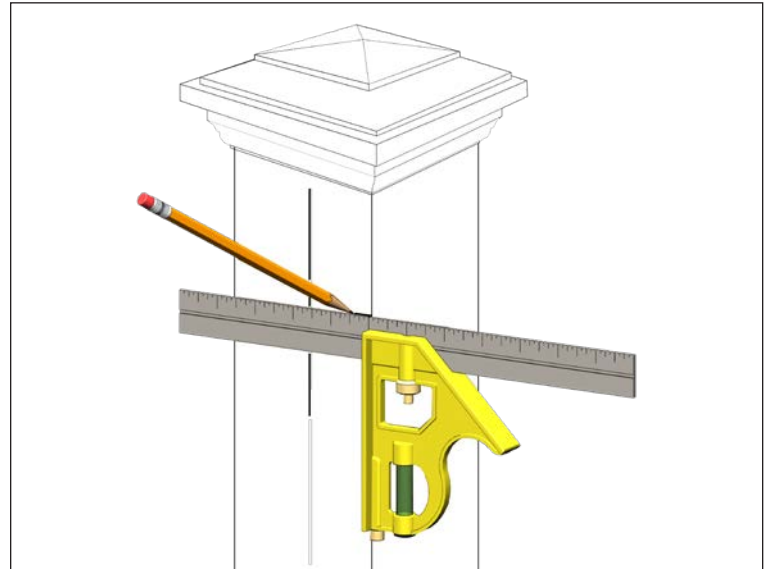
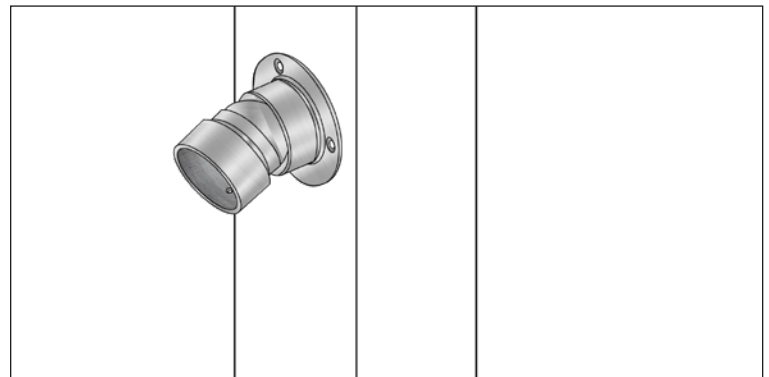

Figure V. Use a square and tape measure to mark the center of your posts.



THE RAILING WILL NEED TO BE REMOVED TO MOUNT RAILEASY CABLE HARDWARE DIRECTLY UNDER THE TOP RAIL. IT IS EASIER TO MARK AND INSTALL THE RAILEASY CABLE HARDWARE ON THE FIRST 2 OR 3 POSITIONS UNDER THE RAIL WITH THE RAIL TILTED UP AND OUT OF THE WAY. IF YOU ARE USING SLEEVED POST AND DRILLING THROUGH MID POST YOU WILL NEED TO REMOVE THE ENTIRE RAIL AND REMOVE THE POST SLEEVE.

Assemble and mount one stair section at a time. Starting with the bottom post pre-drill your marked holes and fasten the adjustable sidemount with #10 x 1 1/2" screws (supplied). You may need to remove the rail and adjust the fitting to reach one of the screws. Rotate your railing down and align the holes marked on the upper post. Recheck the rail height measurement from the nose of the first step down. Tilt the rail back up drill and the holes. Depending on fit and your preference you may fit snug the bottom adjustable sidemount with an 8 mm (5/16") Allen wrench. You will need to remove the tube and tighten this from within cup of the fitting. Make sure you maintain the angle when you do this. Once final adjustment is made you can proceed with mounting the upper adjustable sidemount. Once a section is complete you must tighten the set screw on the bottom of the fitting using a 3 mm Allen wrench.

Repeat these steps for each stair rail section.

Assemble the Rails

Begin with the adjustable angle on the bottom post. Install the flange separate from the rail. You can move the fitting out of the way to screw in the top screw. Fasten the fitting with three (3) #10 x 1-1/2" screws (supplied). Rotate the railing down and line up the top holes with the pre-drilled holes from the previous step (See Figure W). Fasten this fitting with three (3) #10 x 1-1/2" screws (supplied). You should always make sure the set screw in the bottom of the mounting bracket is tightened after the rails are properly placed.

Tighten down the screw using an 8 mm (5/16") Allen wrench as far as you can while still maintaining the adjustability of the angle of the adjustable sidemount (See Figure X).

Additional Tools: A 3 mm Allen wrench is necessary for tightening the sidemount set screw and an 8 mm (5/16") Allen wrench is necessary for tightening the desired angle of the adjustable sidemount.



IF INSTALLING THE MICRO STAR LED LIGHTING, PLEASE REFER TO THE MICRO STAR INSTALLATION INSTRUCTIONS FOR RAILEASY SYSTEMS.

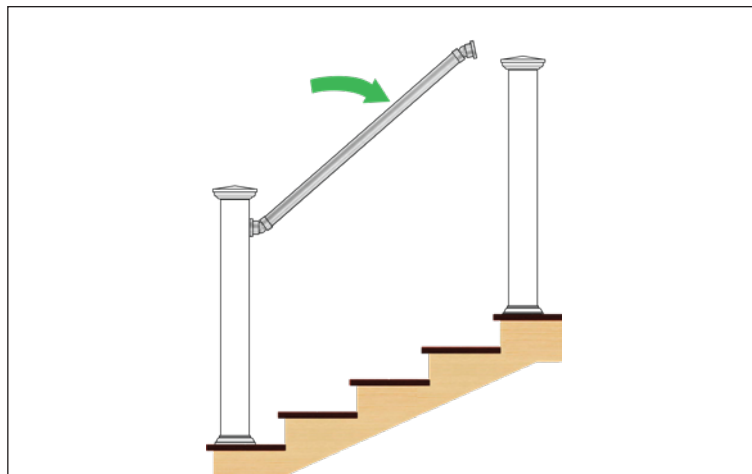

Figure W. Rotate the railing down and line up the top holes with the pre-drilled holes from the previous step.

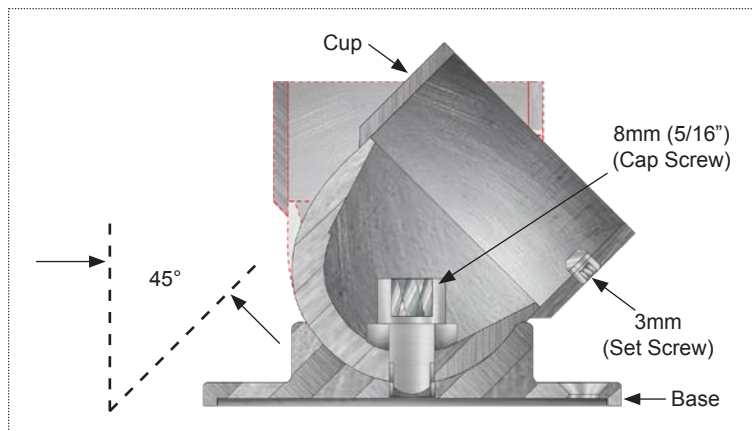

Figure X. Tighten down the screw of the Rail Side Mount Adjustable 2.

Dry Fit Stair Rail Sections

Before Installing the rail, it is important to be sure that the length of tubing is correct for the rail section. With a partner, place adjustable fittings adjustable sidemounts on either end of the appropriate tube. Slide assembly between two posts and adjust accordingly. Measure vertically 36" from the edge of the nosing of the stair. This is the height of the top of the rail (See Figure Y). Measure again from a different tread and make sure that the entire length of the rail is 36" above the leading edge of each tread. With the rail mocked up in place, mark and drill screw holes using a 1/8" drill bit. Be sure that the set screws are facing down.

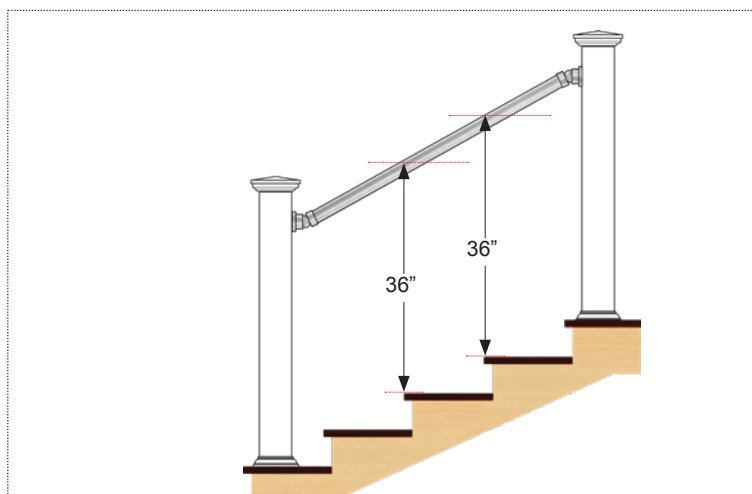

Figure Y. Measure vertically 36" from the edge of the nosing of the stair. This is the height of the top of the rail.

RailEasy Tensioner (C0981 Series)

Atlantis Rail offers a swiveling component to accommodate stairs, ramps, and other angled cable sections. This is the RailEasy Tensioner (C0981 Series). The RailEasy Tensioner is installed with three (3) #8 x 1-1/2" wood screws and swivels up to 45 degrees.

Measure and Mark your Posts

As in the previous section, begin by determining the number of cables you need to maintain code compliance.



ATLANTIS RAIL REQUIRES SPACING YOUR CABLE AT 3" ON CENTER TO HELP AVOID ANY POTENTIAL BUILDING INSPECTION OR SAFETY ISSUES.

As before, find the center of your posts and draw a vertical line. Snap a chalk line parallel to the slope of the stairs at the height of your lowest cable run. Measure for your other cables 3" on center perpendicular to that line (See Figure Z). Snap a chalk line for each cable run. Using a carpenter's square, transfer a line to the inside post face to find the center of your cable (See Figure AA). Where this line intersects the vertical line is the center point for your cable.

Use Your Fittings as a Guide

On the end posts, place the center of your tensioner on the marks made in the previous section. Carefully mark and pre-drill the centers of the fastener holes using a 1/8" drill bit. The RailEasy Tensioner base uses three (3) #8 screws. When installing tensioners on stairs make sure the notch is facing vertical allowing the 45° of motion up or down. As an additional component Atlantis Rail offers a drilling template that has hole patterns laid out for ease of use. See below for more information.

RailEasy Swivel End (C0981-S Series)

Atlantis Rail offers a swiveling component to accommodate stairs, ramps, and other angled cable sections. This is the RailEasy Swivel End (C0981-S Series). The RailEasy Swivel End is installed with three (3) #8 x 1-1/2" wood screws and swivels up to 45 degrees. Measure for and install the swivel end in the same fashion as the steps for the RailEasy Tensioner above. The swivel end needs a tensioning device on the other end of the cable run to tension the cable.

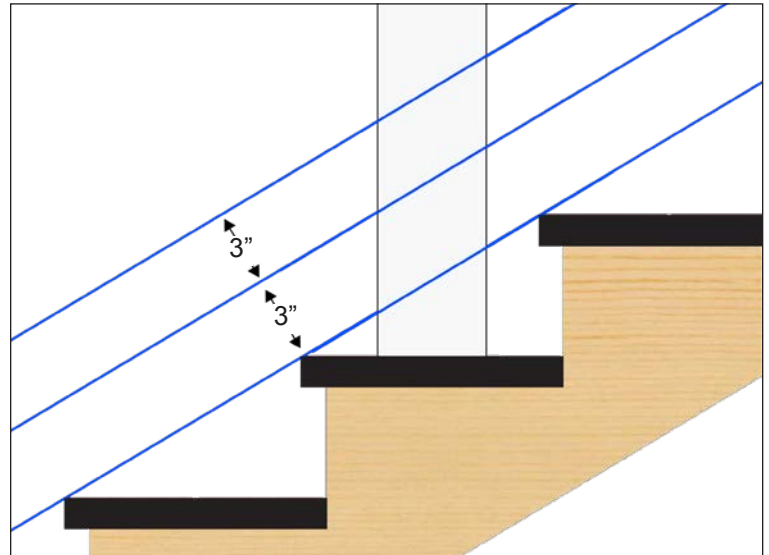

Figure Z. Measure perpendicularly from the chalk line to find the center line of your cables.

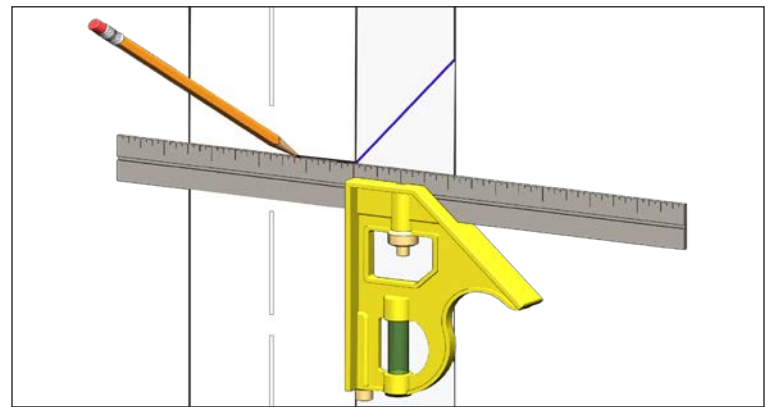

Figure AA. Using a carpenter's square, transfer the chalk line to the inside face of the post. The intersection of this line and the vertical will mark your center.

Additional Components: Atlantis Rail offers a drilling template (C0988-1000) to help with the installation of the RailEasy Tensioner. It has the circular hole pattern of the RailEasy Tensioner base spaced conveniently at three inches on center to make laying out your cable easy.



RailEasy Tensioner (C0981 Series)

Measure & Run the Cable

With the tensioners installed (See Figure AB), begin by extending the threaded stud outward a minimum of 3/4" for the first 20 feet plus 1/4" for each additional 10 feet. To insert the cable into the receiver cone, push and twist the cable opposite the lay of the wire strands. The cable should slide into the receiver cone until approximately 3/16" past the bottom of the wedge (See Figure AC). Fully tighten the receiver cone onto the threaded stud using 7/16" and 3/8" open wrenches. Upon doing this, the wedge will crimp down on the cable and hold it in place. With the cable installed in one tensioner, pull the cable to the opposite tensioner. Pull the cable tight to the tensioner and cut it (See Figure AD). Using the first run as a guide, cut the remaining runs to the same length. This will ensure uniformity among the tensioners. Thread the cable through each mid post and install the cable into the opposite tensioner using the same process as before.

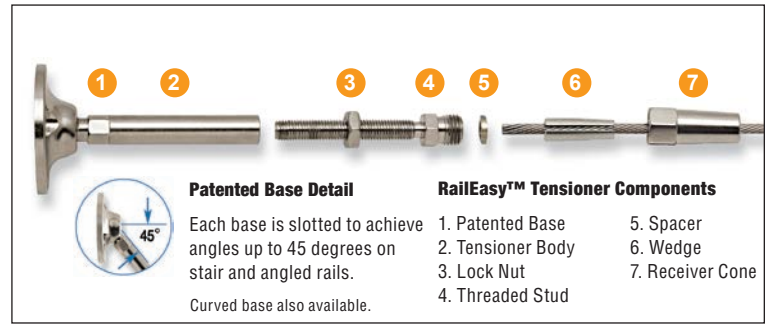

Figure AB. Exploded view of the RailEasy Tensioner for easy identification of each component.

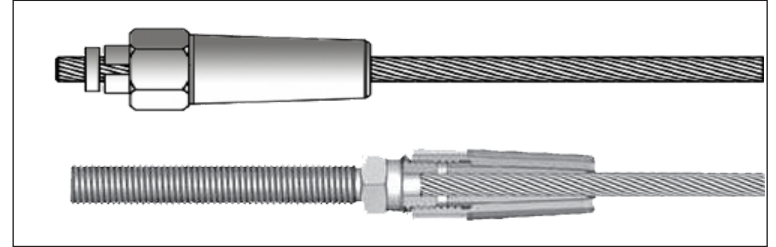

Figure AC. Cutaway view of the RailEasy Tensioner

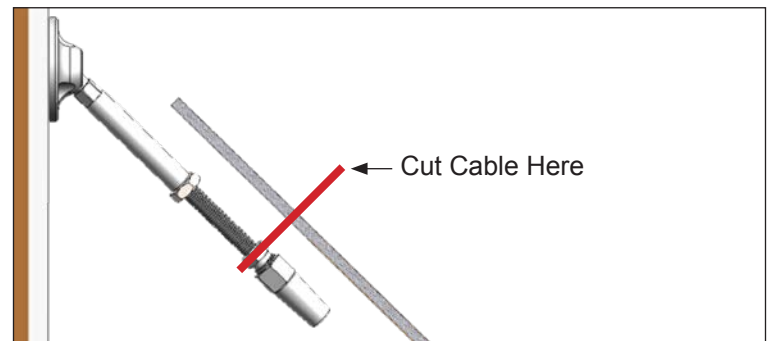

Figure AD. Pull the cable tight to the tensioner and cut it.

RailEasy Swivel End (C0981-S Series)

The swivel end must be used in conjunction with a RailEasy Tensioner in order to tension cable. Follow the same process as above to cut and install the cable (See Figure AE).

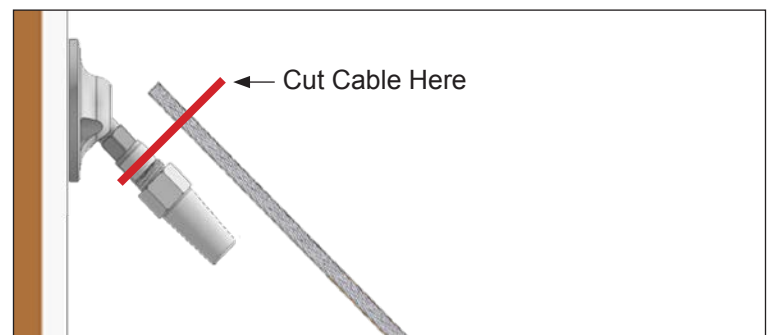

Figure AE. Pull the cable tight to the swivel end and cut it.

Stair & Ramp Section - Tensioning the Cable



BEFORE TENSIONING ANY OF THE CABLES, IT IS IMPORTANT TO BE SURE THAT THE FRAME FOR THE INFILL IS COMPLETED.

Make sure the posts are installed securely and in accordance with the manufacturers' recommended installation procedures. Install all top and intermediate rails. The posts will deflect beyond allowable limits if you attempt to tension the cables on an incomplete guard frame.

RailEasy Tensioner (C0981 Series)

Tension the Center Cable

Before tensioning with tools, hold the threaded stud firm and rotate the tensioner body by hand until all cables are snug.

Beginning with the center run of cable, hold the threaded stud firm using a 3/8" wrench. Using a 5/16" open wrench, rotate the tensioner body to tension the cable (See Figure AF). Turn the body three or four full rotations until cable is snug. Don't worry if this cable moves a little, we will come back around to it later. Tension cable equally from both ends of each cable span. Tighten Lock Nut to secure tension. For additional instructions refer to the RailEasy Tensioner installation instructions.

Tension the Remaining Cables

Alternate tensioning the cables from center, working above and below the center cable as if tightening the lug nuts on a tire (See Figure AG). Rotate the body three or four full rotations or until cable is snug. You will notice as you tension, the cables surrounding it will slacken. When this begins happening, stop tensioning and move onto the next cable.

Make Final Adjustments

Go back to the center cable and re-tighten the cables until all are tight and relatively equal in tension. You may find that you need to do this three or four times getting down to even a quarter turn of the tensioner body each time. Tension from both sides when necessary. Add "Non-Acidic" Silicone Sealant to open tip of Receiver Cone in harsh environments.

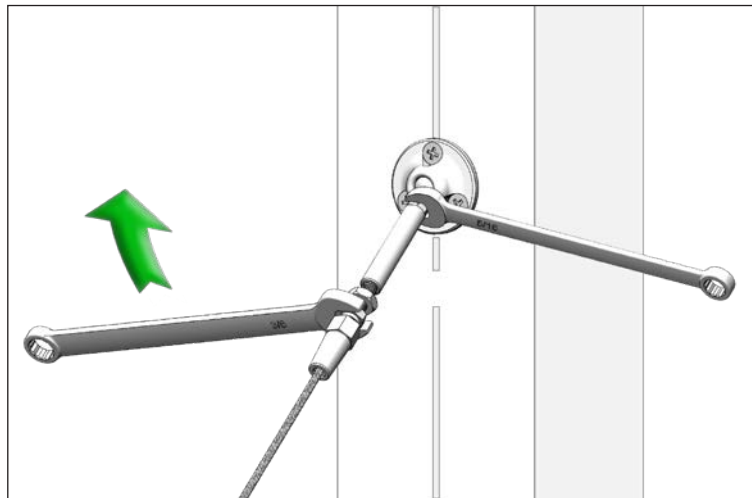

Figure AF. Hold the tensioner terminal still with a 3/8" wrench and using a 5/16" open wrench, rotate tensioner body to tension.



ALWAYS USE WORK GLOVES AND WEAR SAFETY GLASSES TO PROTECT YOUR HANDS AND EYES WHILE WORKING WITH CABLE. DO NOT OVER-TENSION.

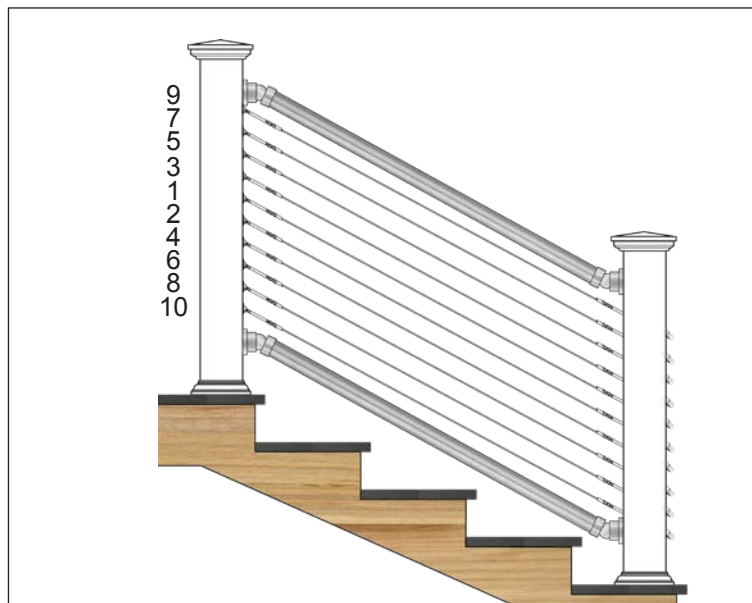

Figure AG. Tensioning Diagram - Begin with the center run of cable and alternate working above and below until cables are tight.

Additional Components

Acorn Nut Set*



C0308-UF07-2

Designed for use with RailEasy Stud Assembly. This set is perfect for cable railing systems where “through post” hardware is desired for minimal obstruction. Affix the stainless steel acorn nut set to the end of a stud assembly for a finished look (See Figure AH). Finish: Polished Stainless Steel. Available in 2 packs.

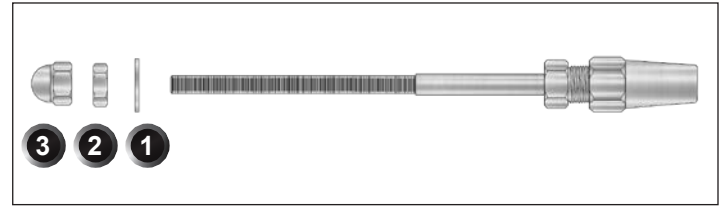

Figure AA Acorn Nut Set assembly diagram - 1) Stainless Steel Washer, 2) Stainless Steel Nut & 3) Stainless Steel Acorn Nut.

* The Acorn Nut Set comes with the RailEasy Stud Assembly or sold separately.

Deluxe Cover Nut Set



C0307-UF07-2

Designed for use with the RailEasy Stud Assembly. The Cover Nut Set is perfect for cable railing systems where “through-post” hardware is desired for minimal obstruction. Affix to the end of the stud assembly for a finished look (See Figure AI). Finish: Polished Stainless Steel. Available in 2 packs.

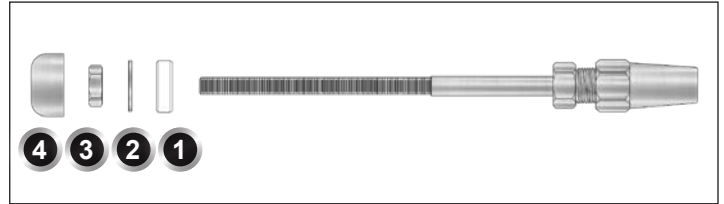

Figure AI. Deluxe Cover Nut Set assembly diagram - 1) Plastic Washer, 2) Stainless Steel Washer, 3) Stainless Steel Nut & 4) Stainless Steel Deluxe Cover. RailEasy Stud Assembly not included.

HandiSwage Cover Nut Sets



C0309 Series

Designed for use with RailEasy Stud Assembly. Cover Nut Sets are perfect for cable railing systems where “through-post” hardware is desired for minimal obstruction. Affix to end of stud assembly for a finished look (See Figure AJ). Finishes: White, Brown, Metallic Silver and Black. Available in 10 packs.

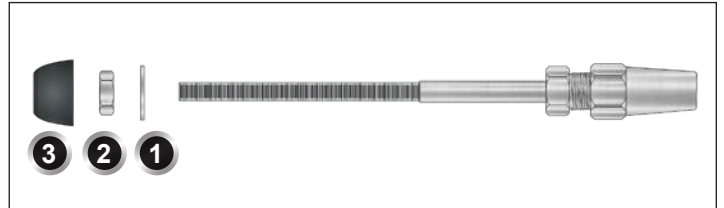

Figure AJ. HandiSwage Cover Nut Set assembly diagram - 1) Stainless Steel Washer 2) Stainless Steel Nut & 3) HandiSwage Cover. RailEasy Stud Assembly not included.

RailEasy Cable Sleeve



C0915-0438

The RailEasy Cable Sleeve is designed to protect your wood posts from chafing and incidental damage from cable rubbing around the outside of your mid post cable holes. It can also be used to accommodate angles up to 90 degrees (double posts required) and stairways coming off a straight run (See Figures AK and AL). These sleeves are made from grade 316L stainless steel for corrosion resistance and durability.

For the mid posts, use a 1/4” drill bit and drill completely through the posts. Again, drilling from either side of the post and meeting in the middle will help you hit your centers and make for a neater installation. Place a cable sleeve in each drilled hole and tap into place with a rubber mallet.

For detailed instructions refer to the Cable Sleeve Installation Instructions.

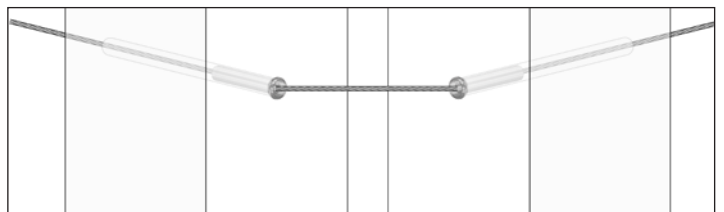

Figure AK. Cable Sleeve Diagram - Accommodating angles up to 90 degrees. Doubling up on corner posts is required.

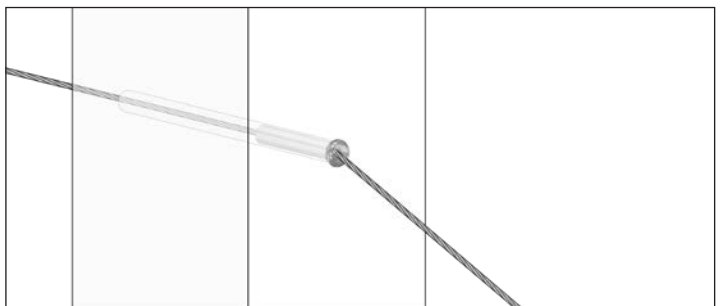
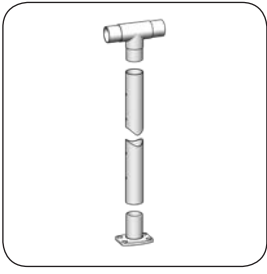

Figure AL. Cable Sleeve Diagram - Accommodating a stairway coming off a straight run.

RailEasy Mid Post



S0973-MP Series
(Mid Post)
(316L Stainless Steel)

The Mid Post is designed specifically for use where post to post measurement spans over 4'. It enables you to adapt longer spans to code compliance by stabilizing the deflection of cable between posts. The mid posts are available in 36" or 42" stanchions pre-drilled to work with our standard 3" spacing. Apply a thin bead of Loctite 326 brand adhesive to the post base and rail tee when you are comfortable that the dry-fit sections are correct (See *Figure AM*). The mid post should never be used in spans over 6'. The mid post includes fasteners.

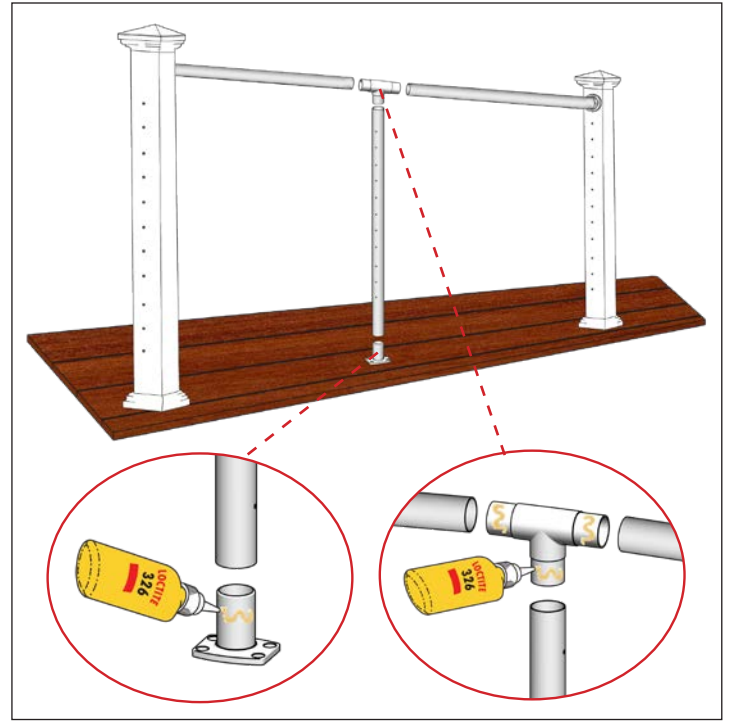
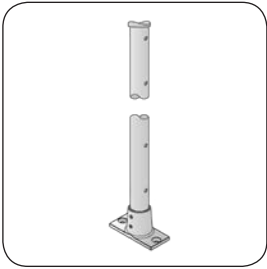

Figure AM. Apply a thin bead of Loctite 326 brand adhesive to the post base and rail tee when you are comfortable that the dry-fit sections are correct.

Cable Stabilizer



S0950-0061
(Cable Stabilizer)
(316L Stainless Steel)

The Cable Stabilizer is designed specifically for use where post to post measurement spans over 4'. It enables you to adapt longer spans to code compliance by stabilizing the deflection of cable between posts. Each stabilizer comes with a 42" stanchion pre-drilled to work with our standard 3" spacing. In most cases, stanchions must be field cut at both ends for an accurate fit. The cable stabilizer cannot be used to replace the use of substantial mid posts and should never be used in spans over 7'. The cable stabilizer includes fasteners.

For detailed instructions refer to the Cable Stabilizer Installation Instructions.

With base and top plate in the desired center position mark the screw hole (top and bottom) in the hand rail and the mounting surface with a pencil (See *Figure AN*). Remove the stabilizer connector and tap a dimple into the top rail with a center punch and hammer. Remove post kit from between the top rail and decking. Drill a pilot hole using a 5/32" drill bit where the screw hole was marked with the center punch. Also drill pilot holes into the mounting surface. Assemble the cable stabilizer with fasteners.

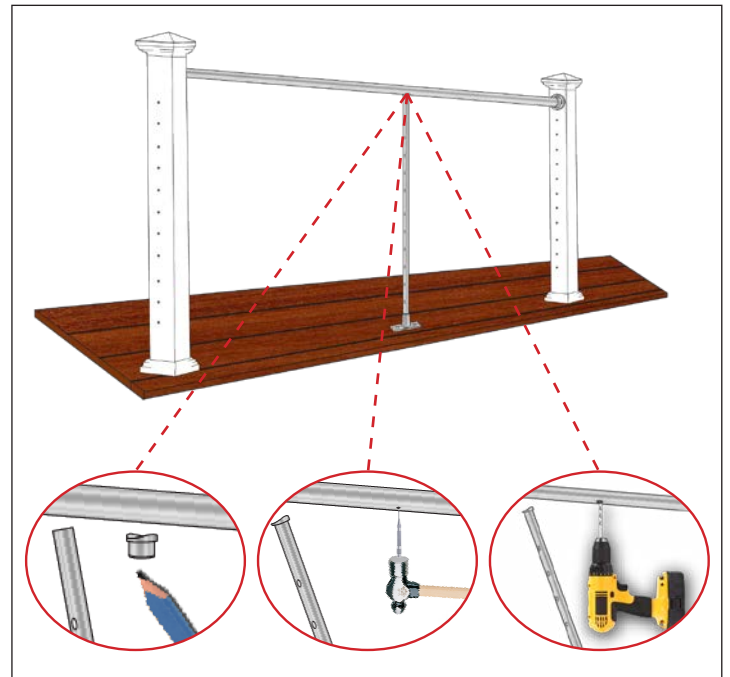

Figure AN. With base and top plate positioned as desired mark the screw holes (top and bottom), remove stabilizer, tap and drill pilot holes.



USE A CENTER PUNCH TO PUT A DIMPLE IN THE TOP RAIL TUBE BEFORE DRILLING.

RailEasy Nautilus System Specifications

The RailEasy Nautilus System uses either pre-existing or new railing posts. Recommended posts are standard 4' x 4" wood. Other materials may be used at your own discretion, but be aware that tension must be applied to tensioners and cable. Posts should be capable of receiving the mounting screws and holding under tension.

Straight Sections

Atlantis Rail offers standard rail heights of 36" or 42" for straight sections.

Stair Sections

Rail height for stair sections is available in 36" only.



RAILING HEIGHTS ARE OFFERED IN THESE DIMENSIONS DUE TO NATIONWIDE BUILDING CODES. HOWEVER, ATLANTIS RAIL CAN SUPPLY CUSTOM HEIGHTS/LENGTHS UPON REQUEST.

Between Posts Length

Atlantis Rail recommends staying within 4' section lengths to maintain structural integrity.

Railing Finish

The RailEasy™ Nautilus handrails and optional bottom rails are offered in a highly polished or brushed finish.

Cable Spacing

The cable is spaced on posts at 3" on-center to comply with nationwide building codes.

RailEasy Nautilus Product Specifications

Components

Product	Description	Dimensions	Fasteners	Notes
C0978-4025	5/32" Cable, 25ft. Spool	5/32" 1x19 316L stainless steel cable	--	--
C0978-4100	5/32" Cable, 100ft. Spool	5/32" 1x19 316L stainless steel cable	--	--
C0978-4500	5/32" Cable, 500ft. Spool	5/32" 1x19 316L stainless steel cable	--	--
C0981-0204	RailEasy Tensioner (2 Pack)	5.40" length 1/4"-28 RH thread	(3) #8 x 1-1/2"	Adjustable
C0981-1004	RailEasy Tensioner (10 Pack)	5.40" length 1/4"-28 RH thread	(3) #8 x 1-1/2"	Adjustable
C0981-S024	RailEasy Swivel End (2 Pack)	2.26" length 1/4"-28 RH thread	(3) #8 x 1-1/2"	Adjustable
C0981-S104	RailEasy Swivel End (10 Pack)	2.26" length 1/4"-28 RH thread	(3) #8 x 1-1/2"	Adjustable
S0981-P004	RailEasy Flush Fitting	1.29" length	--	--
C0980-0004-2	RailEasy Stud Assembly	4.50" shank length 1/4"-28 RH thread	--	Comes with acorn nut set
C0980-R004-2	RailEasy Lag Stud (2 Pack)	2.25" shank length	--	--
C0841-0030-2	Stair Spacer (2 Pack)	1/4" 30° .500" Length .750" OD	--	--
C0841-0034-2	Stair Spacer (2 Pack)	1/4" 34° .500" Length .750" OD	--	--
C0841-0038-2	Stair Spacer (2 Pack)	1/4" 38° .590" Length .750" OD	--	--
C0915-0438	RailEasy Cable Sleeve (10 Pack)	1.500" length .190" ID, .250" OD	--	--
C0309-WH02-10	HandiSwage Cover Nut Set (10 Pack)	.420" length .690" OD (White)	--	1/4"-28 RH thread UNF
C0309-BR02-10	HandiSwage Cover Nut Set (10 Pack)	.420" length .690" OD (Brown)	--	1/4"-28 RH thread UNF
C0309-BK02-10	HandiSwage Cover Nut Set (10 Pack)	.420" length .690" OD (Black)	--	1/4"-28 RH thread UNF
C0309-MT02-10	HandiSwage Cover Nut Set (10 Pack)	.420" length .690" OD (Metallic Silver)	--	1/4"-28 RH thread UNF
C0308-UF07-2	Acorn Nut Set (2 Pack)	.674" complete assembly	--	1/4"-28 RH thread UNF
C0307-UF07-2	Deluxe Cover Nut Set (2 Pack)	.400" length .750" OD	--	1/4"-28 RH thread UNF
C0975-0002	RailEasy Straight Sidemount	2" 316L stainless steel	(3) #10 x 1-1/2"	2 Pack
C0976-0002	RailEasy Adjustable Sidemount	2" 316L stainless steel	(3) #10 x 1-1/2"	2 Pack
C0973-0900	RailEasy Tubing	2" x 36" 316L stainless steel	--	Polished finish
C0973-1200	RailEasy Tubing	2" x 48" 316L stainless steel	--	Polished finish
C0973-1500	RailEasy Tubing	2" x 60" 316L stainless steel	--	Polished finish
S0973-MP36	RailEasy Mid Post Kit	36" Length 316L Stainless Steel	--	Includes fasteners
S0973-MP42	RailEasy Mid Post Kit	42" Length 316L Stainless Steel	--	Includes fasteners
S0950-0061	Cable Stabilizer	42" Length 316L Stainless Steel	--	--

S0983-1000	RailEasy Sleeve	48" Length 4" x 4"	--	White Vinyl
S0984-0000	RailEasy Colonial Post Cap	4.02" x 4.02"	--	White Vinyl
S0984-0001	RailEasy Colonial Post Base	4.03" x 4.03"	--	White Vinyl
C0988-0000	RailEasy Installation Tools	--	--	--
C0988-1000	RailEasy Drill Template	--	--	3" on center
C0989-00HD	RailEasy Cable Cutter	--	--	--